

**TECHNICAL MANUAL  
ORGANIZATIONAL MAINTENANCE  
MANUAL**

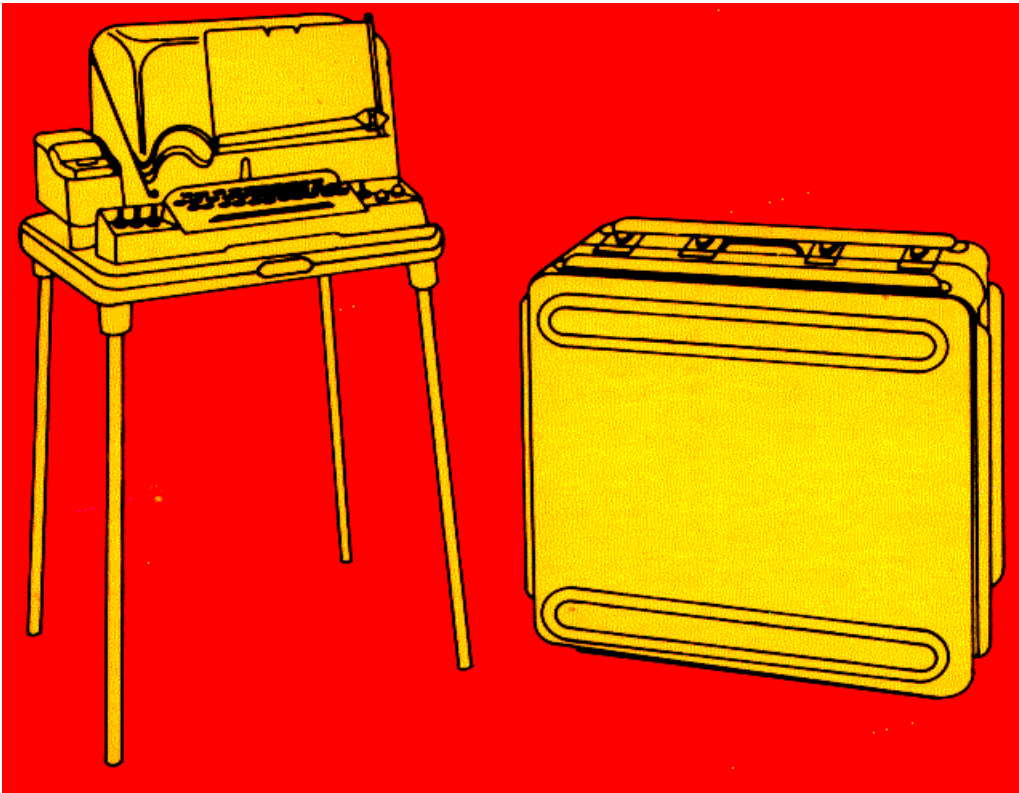

**TECHNICAL  
PRINCIPLES  
OF OPERATION  
PAGE 1-3**

**SERVICE  
UPON RECEIPT  
Page 2-1**

**INSTALLATION  
INSTRUCTION  
Page 2-5**

**TROUBLE-  
SHOOTING  
Page 2-18**

**MAINTENANCE  
PROCEDURES  
Page 2-29**

**MAINTENANCE  
ALLOCATION  
CHART (MAC)  
Appendix B**

**TELETYPEWRITER SETS  
AN/GGC-3 (NSN 5815-00-503-3309)  
AN/GGC-3A (NSN 5815-00-581-9751)  
AN/GGC-53 (NSN 5815-01-012-8772)  
AN/GGC-53A (NSN 5815-01-017-0956)**

**AND**

**TELETYPEWRITER REPERFORATOR-TRANSMITTERS  
TT-76/GGC (NSN 5815-00-503-2760)  
TT-76A/GGC (NSN 5815-00-553-6061)  
TT-76B/GGC (NSN 5815-00-553-6061)  
TT-76C/GGC (NSN 5815-00-553-6061)  
TT-699/GGC (NSN 5815-01-012-8446)  
TT-699A/GGC (NSN 5815-01-017-9166)  
TT-699B/GGC (NSN 5815-01-017-9166)  
TT-699C/GGC (NSN 5815-01-017-9166)**

**HEADQUARTERS, DEPARTMENT OF THE ARMY  
WASHINGTON, D.C.**

**28 SEPTEMBER 1983**



**5**

**SAFETY STEPS TO FOLLOW IF SOMEONE IS THE VICTIM OF ELECTRICAL SHOCK**

**1**

**DO NOT TRY TO PULL OR GRAB THE INDIVIDUAL**

**2**

**IF POSSIBLE, TURN OFF THE ELECTRICAL POWER**

**3**

**IF YOU CANNOT TURN OFF THE ELECTRICAL POWER, PULL, PUSH, OR LIFT THE PERSON TO SAFETY USING A WOODEN POLE OR A ROPE OR SOME OTHER INSULATING MATERIAL**

**4**

**SEND FOR HELP AS SOON AS POSSIBLE**

**5**

**AFTER THE INJURED PERSON IS FREE OF CONTACT WITH THE SOURCE OF ELECTRICAL SHOCK, MOVE THE PERSON A SHORT DISTANCE AWAY AND IMMEDIATELY START ARTIFICIAL RESUSCITATION**

**WARNING**

**HIGH VOLTAGE** is used in operation of this equipment. **DEATH ON CONTACT** may result if you fail to follow safety requirements in this manual as well as in TB SIG 291.

**DON'T TAKE CHANCES!**

Turn all equipment to **OFF** before making any corrections or replacing any parts inside the equipment.

This equipment contains selenium rectifiers which instantly send out poisonous fumes when they burn out. The smell is like rotten eggs. If you should smell this, get fresh air quickly; provide thorough ventilation at all times.

Fumes of **TRICHLOROTRIFLUOROETHANE** are poisonous; provide thorough ventilation whenever it is used. Do not use it near open flames or a hot surface. Do not get it on your skin.

A/(B blank)

**ORGANIZATIONAL MAINTENANCE MANUAL  
TELETYPEWRITER SETS**

**ANIGGC-3 (NSN 5815-00-503-3309)  
ANIGGC-3A (NSN 5815-00-581-9751)  
ANIGGC-53 (NSN 5815-01-012-8772)  
ANIGGC-53A (NSN 5815-01-017-0956)**

**AND**

**TELETYPEWRITER REPERFORATOR-TRANSMITTERS**

**TT-76/GGC (NSN 5815-00-503-2760)  
TT-76AIGGC (NSN 5815-00-553-6061)  
TT-76BIGGC (NSN 5815-00-553-6061)  
TT-76C/GGC (NSN 5815-00-553-6061)  
TT-6991GGC (NSN 5815-01-012-8446)  
TT-699A/GGC (NSN 5815-01-017-9166)  
TT-699BIGGC (NSN 5815-01-017-9166)  
TT-699CIGGC (NSN 5815-01-017-9166)**

**REPORTING OF ERRORS AND RECOMMENDING IMPROVEMENTS**

You can help improve this manual. If you find any mistakes or if you know of a way to improve the procedures, please let us know. Mail your letter, DA Form 2028 (Recommended Changes to Publications and Blank Forms), or DA Form 2028-2 located in back of this manual direct to: Commander, US Army Communications Electronics Command and Fort Monmouth, ATTN: DRSEL-ME-MP, Fort Monmouth, New Jersey 07703. In either case, a reply will be furnished direct to you.

		PAGE
	HOW TO USE THIS MANUAL .....	iii
CHAPTER 1	INTRODUCTION .....	1-1
Section I	General Information .....	1-1
II	Equipment Description and Data .....	1-2
III	Technical Principles of Operation .....	1-3
CHAPTER 2	MAINTENANCE INSTRUCTIONS .....	2-1
Section I	Repair Parts, Special Tools, and Support Equipment .....	2-1
II	Service Upon Receipt .....	2-1
III	Installation Instructional .....	2-5
IV	Preventive Maintenance Checks and Services (PMCS) .....	2-15
V	Troubleshooting .....	2-18
VI	Maintenance Procedures .....	2-29
VII	Preparation for Storage and Shipment .....	2-32

\*This manual together with TM 11-5815-238-10, 18 July 1983 supersedes TM 11-5815-238-12, 6 December 1965.

PAGE  
APPENDIX A REFERENCES .....  
          B MAINTENANCE ALLOCATION CHART (MAC) .....  
          C EXPENDABLE SUPPLIES AND MATERIALS LIST .....  
GLOSSARY  
INDEX

A-1  
B-3  
C-1  
Glossary-1  
Index-1

### HOW TO USE THIS MANUAL

- THIS MANUAL TELLS ABOUT THE TYPICAL ARRANGEMENTS OF THE TELETYPEWRITER REPERFORATOR-TRANSMITTER TT-76/GGC.
- ALL THE PROCEDURES IN THIS MANUAL MUST BE EXAMINED BEFORE YOU BEGIN ANY TASK.
- THROUGHOUT THIS MANUAL COLOR CODED MARGIN TABS WILL GUIDE YOU TO THE SECTION THAT CONTAINS THE SPECIFIC INFORMATION YOU NEED.
- THIS MANUAL IS ORGANIZED INTO CHAPTERS, SECTIONS, PARAGRAPHS AND ILLUSTRATIONS WHICH ARE NUMBERED TO HELP YOU FIND INFORMATION ABOUT YOUR EQUIPMENT QUICKLY AND EASILY.
- COLOR IS USED TO EMPHASIZE KEY POINTS.
- UNFAMILIAR WORDS WILL BE EXPLAINED AT THE BEGINNING OF EACH CHAPTER.
- THE SUBJECT INDEX IN THE BACK OF THE MANUAL WILL HELP YOU FIND INFORMATION QUICKLY.

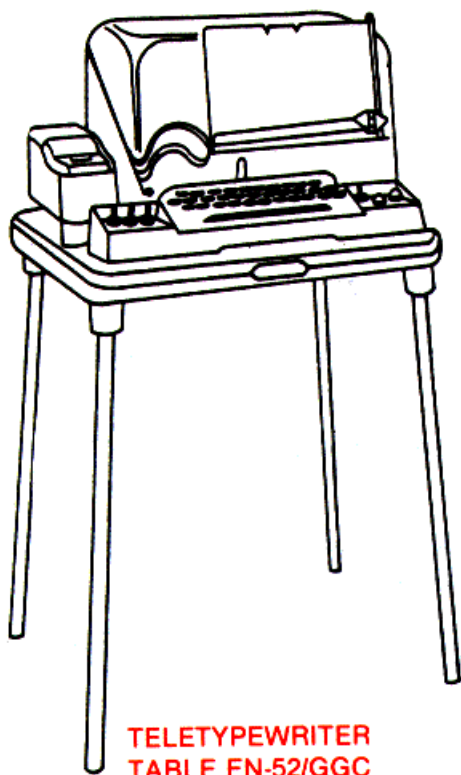

TELETYPEWRITER  
TABLE FN-52/GGC

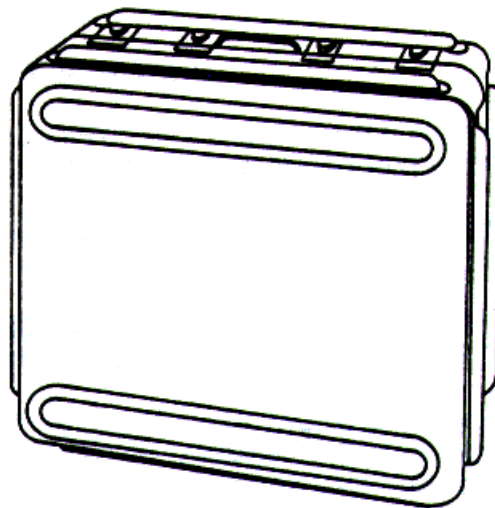

CASE  
CY-110/GGC

TELETYPEWRITER REPERFORATOR-TRANSMITTER TT-76/GGC

CHAPTER 1

INTRODUCTION

Section I. GENERAL INFORMATION

1-1. SCOPE

- TYPE OF MANUAL: Organizational Maintenance
- EQUIPMENT NAME AND MODEL NUMBER:

**High Level Equipment**

Teletypewriter Set	ANIGGC-3
Teletypewriter Reperforator-Transmitter	TT-76/GGC
Teletypewriter Set	ANIGGC-3A
Teletypewriter Reperforator-Transmitter	TT-76AIGGC

**Low Level Equipment**

Teletypewriter Set	TT-76B/GGC
Teletypewriter Reperforator-Transmitter	TT-76CIGGC
Teletypewriter Set	ANIGGC-53
Teletypewriter Reperforator-Transmitter	TT-699/GGC
	AN/GGC-53A
	TT-699AIGGC
	TT-699BIGGC
	TT-699CIGGC

The ANIGGC-3(\*) and TT-76(\*)/GGC are high-level equipment which operate with a line current of 20 or 60mA (milliamperes). The ANIGGC-53(\*) and TT-699(\*)IGGC are low-level equipment which operate with a line current of approximately 100 mallow-level equipment is high-level equipment which has been modified for low-level signaling operation.

- PURPOSE OF EQUIPMENT: Teletypewriter Sets AN/GGC-3(\*) and AN/GGC-53(\*) are lightweight, transportable units which can be used in either fixed or mobile teletypewriter stations. They provide facilities for manual transmission direct from keyboard and for tape transmission from transmitter-distributor. Received messages are printed and perforated on paper tape for later transmission.

Teletypewriter Reperforator-Transmitters TT-76(\*)IGGC are used to send and receive over direct current (dc) wirelines carrier, or radio systems when used with Telegraph Terminal TH-5/TG, or similar line terminating devices.

Teletypewriter Reperforator-Transmitters TT-699(\*)IGGC are used to send and receive over dc (6-volt polar) signal circuits only.

**NOTE**

For details on purpose of equipment, refer to Operator's Manual TM 11-5815-238-10.



**1-2. MAINTENANCE FORMS, RECORDS AND REPORTS**

Department of the Army forms and procedures used for equipment maintenance will be those described by TM 38-750, The Army Maintenance Management System (TAMMS).

**1-3. DESTRUCTION OF ARMY MATERIEL TO PREVENT ENEMY USE**

Destruction of Army materiel to prevent enemy use is described in TM 750-244-2.

**1-4. PREPARATION FOR STORAGE AND SHIPMENT**

Description of preparation for storage and shipment are found in Chapter 2, Section VII of this manual.

**1-5. NOMENCLATURE CROSS-REFERENCE LIST NOTE**

**NOTE**

**Official nomenclature must be used when filling out report forms or looking up technical manuals. Official nomenclature followed by an (\*) designates all models of the equipment referenced in this manual.**

**COMMON NAME**

**NOMENCLATURE**

Teletypewriter	Teletypewriter Reperforator-Transmitter TT-76(*)IGGC or Teletypewriter Reperforator-Transmitter TT-699(*)/GGC.
Teletypewriter Set	Teletypewriter Set ANIGGC-3(*) or Teletypewriter Set ANIGGC-53(*).
Chad Bin	Chad Bin, SM 13-157283.
Tuning Fork	Fork, Tuning, SC-DL-70237.
Inking Ribbon	Teletypewriter, Ribbon, DDD-R-311D, type 1, grade 1, class 1.
Printing Ribbon Spool	Spool, Printing Ribbon, pin 10900.
Paper Tape	Tape, Teletypewriter Perforator UU-T-120.

**1-6. REPORTING EQUIPMENT IMPROVEMENT RECOMMENDATIONS (EIR's)**

You can improve this equipment. Tell us if a design is not favorable or if a procedure is difficult to follow. Mail Form SF 368 (Quality Deficiency Report) directly to: Commander US Army Communications Electronics Command and Fort Monmouth, ATTN: DRSEL-ME-MP, Fort Monmouth, New Jersey 07703. A reply will be sent to you.

**Section II. EQUIPMENT DESCRIPTION AND DATA**

**1-7. EQUIPMENT CHARACTERISTICS, CAPABILITIES AND FEATURES**

Refer to Operator's Manual TM 11-5815-238-10.

**1-8. LOCATION AND DESCRIPTION OF MAJOR COMPONENTS**

Refer to Operator's Manual TM 11-5815-238-10.

**1-9. DIFFERENCES BETWEEN MODELS**

Refer to Operator's Manual TM 11-5815-238-10.

**1-10. EQUIPMENT DATA**

Refer to Operator's Manual TM 11-5815-238-10.

**1-11. SAFETY, CARE AND HANDLING**

Observe all WARNING, CAUTIONS and NOTES in this manual. This equipment can be extremely dangerous if these instructions are not followed.

**Section III. TECHNICAL PRINCIPLES OF OPERATION**

**1-12. GENERAL**

Major mechanical components for high-level and low-level equipment are the same while their major electrical components are different. The technical principles of operation for plain and lettered models of teletypewriter reperforator-transmitters are the same.

**1-13. SIGNALING CODE**

- In standard teletypewriter operation, the code for different characters always consists of five units of an equal length of time. These units are called mark pulses and space pulses; the five-unit mark-and-space code group for the letter X is given below.

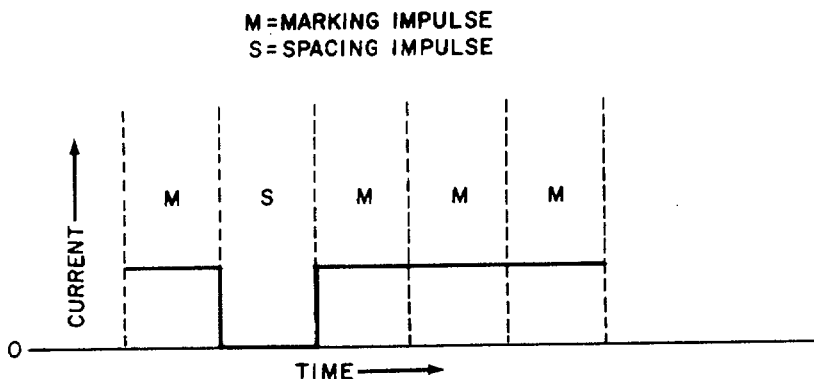

- Standard teletypewriter signals are transmitted by neutral and polar operation. In neutral operation, current flows through a circuit in only one direction. Mark pulses are current pulses, space pulses are non-current pulses. In polar operation, current flows through a circuit in both directions. Mark pulses are current pulses in one direction, space pulses are current pulses in the opposite direction (opposite polarity).
- High-level TT-76(\*)/GFC units are designed to receive both neutral and polar pulses but are wired to send only neutral pulses.
- Low-level TT-699(\*)/GFC units are designed to receive and transmit 6 volt polar pulses only.

1-14. BASIC HIGH-LEVEL TELETYPEWRITER SYSTEM

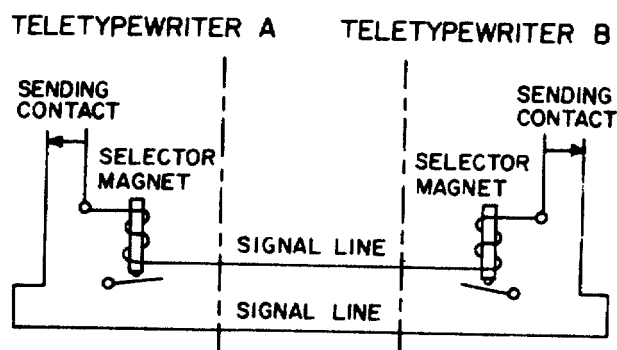

•Pulses sent from either sending contact operates selector magnets in both teletypewriters. Both teletypewriters can send and receive. Additional teletypewriters, sending units and/or receiving units can be added to this system, if needed.

1-15. BASIC LOW-LEVEL TELETYPEWRITER SYSTEM

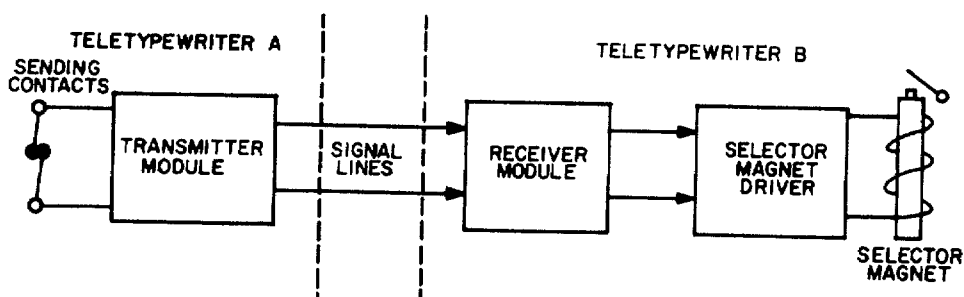

•Mark (negative) and space (positive) pulses are made at sending TELETYPEWRITER A by closing and opening the sending contacts. The transmitter module turns these closings and openings into 6 volt polar signals and applies them to the signal lines. These polar signals are received by TELETYPEWRITER B receiver module and processed through the selector magnet driver to the selector magnet.

•Both teletypewriters are equipped with send and receive components but full two-way communication would require four signal lines and transmitters and receivers interconnected. Additional receiving units may be connected to a sending unit on a parallel basis only.

**CHAPTER 2**  
**MAINTENANCE INSTRUCTIONS**

	PAGE
Assembly .....	2-5
Connections:	
Ground and power .....	2-6
Installation .....	2-5
Maintenance procedures .....	2-29
Preparation for storage and shipment .....	2-32
PMCS table .....	2-17
Service upon receipt .....	2-1
Signal circuit connections.	
for TT-76(*)/GGC . .....	2-9
for TT-699(*)/GGC .....	2-13
Unpacking .....	2-1

**Section I. REPAIR PARTS, SPECIAL TOOLS AND SUPPORT EQUIPMENT**

**2-1. TOOLS AND TEST EQUIPMENT**

Tools and test equipment for Organizational Maintenance of ANIGGC-3(\*) and AN/GGC-53(\*) are listed in the Maintenance Allocation Chart (MAC) in Appendix B of this manual.

**2-2. SPECIAL TOOLS, TMDE AND SUPPORT EQUIPMENT**

There are no special tools or TMDE required for this equipment.

**2-3. REPAIR PARTS**

Repair parts are listed and illustrated in the Repair Parts and Special Tools List TM 11-5815-238-20P covering Organizational Maintenance for this equipment.

**Section II. SERVICE UPON RECEIPT**

**2-4. UNPACKING EQUIPMENT**



**Prevent personal injury when removing steel straps by wearing heavy gloves and protective eyewear. Do not handle shipping container by the steel straps.**

**CAUTION**

**When unpacking equipment, do not push tools inside the shipping container, as equipment may be damaged.**

**NOTE**

Unpacking instructions for Teletypewriter Sets ANIGGC-53(\*) are the same as those given below for AN/GGC-3(\*). Unpacking instructions for Teletypewriter Reperforator-Transmitters TT-699(\*)/GGC are the same as those given below for TT-76(\*)/GGC.

**Teletypewriter Sets ANIGGC-3(\*)**

- Cut steel straps from wooden shipping container. For AN/GGC-3A, use a nail puller to remove nails from cover and sides.
- Remove top, side and back sections.

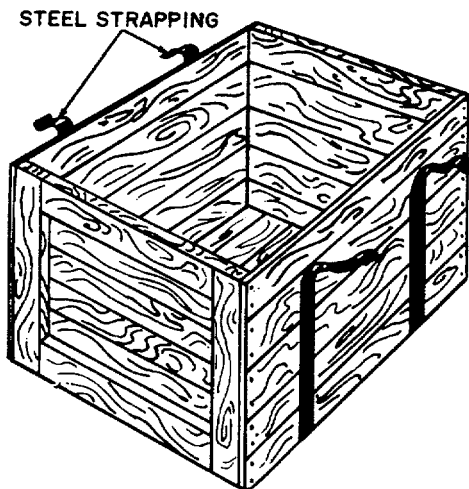

- For AN/GGC-3A, remove corrugated carton and unfasten two technical manuals. Remove case CY-1110/GGC.

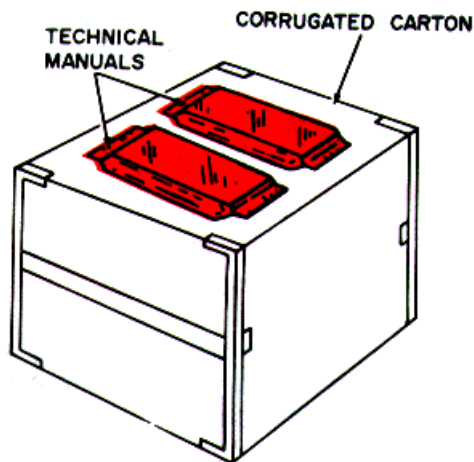
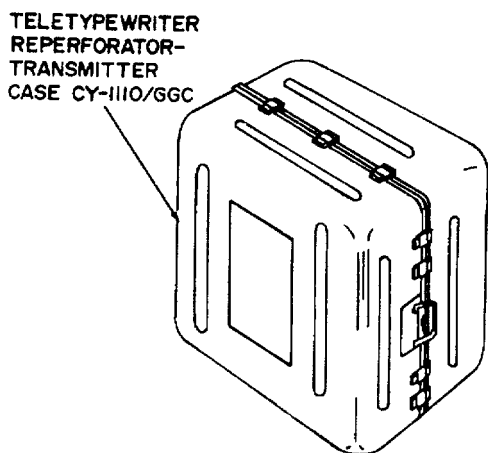

- Release pressure valves on case CY-1110IGGC with a pencil or small screwdriver; unfasten spring-loaded latches on case. Remove top section of CY-1 1101GGC.
- Remove blocking frames that position reperforator-transmitter and table top during transportation. For ANIGGC-3A, remove chad bin accessory pack from one of the frames.
- Remove reperforator-transmitter (TT-761GGC in AN/GGC-3, TT-76A, B, CIGGC in ANIGGC-3A) and table top (FN-52/GGC in ANIGGC-3, FN-1081GGC in ANIGGC-3A).
- Remove table legs from case. For ANIGGC-3, remove chad bin as well.
- Assemble CY-1110/IGGC and store it in a safe place.

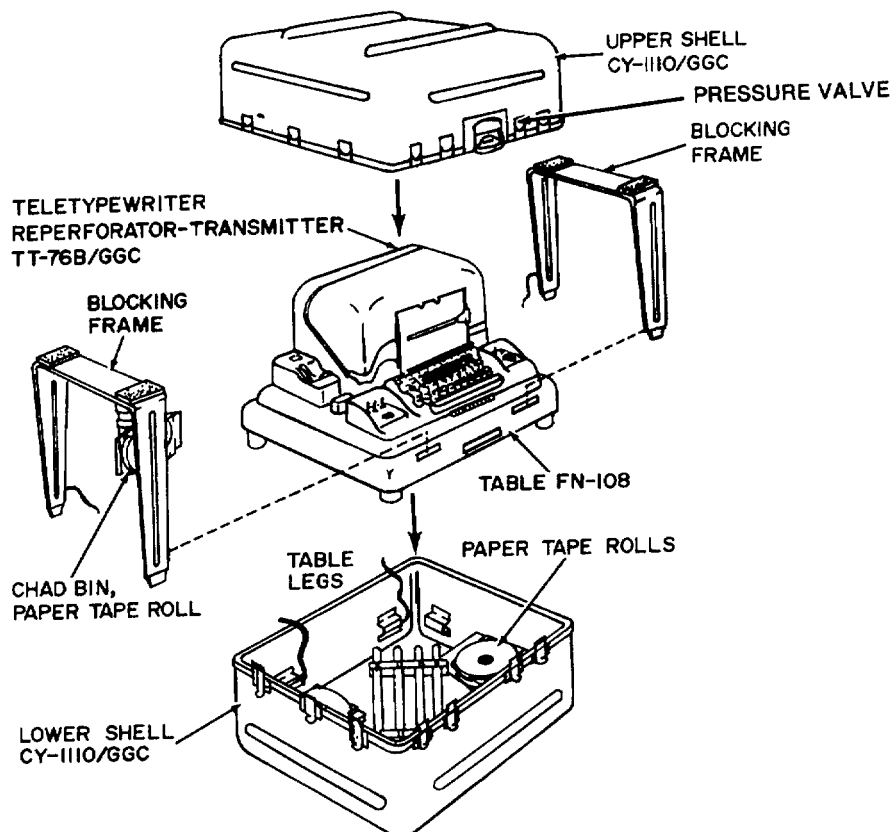

**Teletypewriter Reperforator-Transmitter TT-76(\*)IGGC.**

- Use a nail puller to remove nails from wooden box cover.

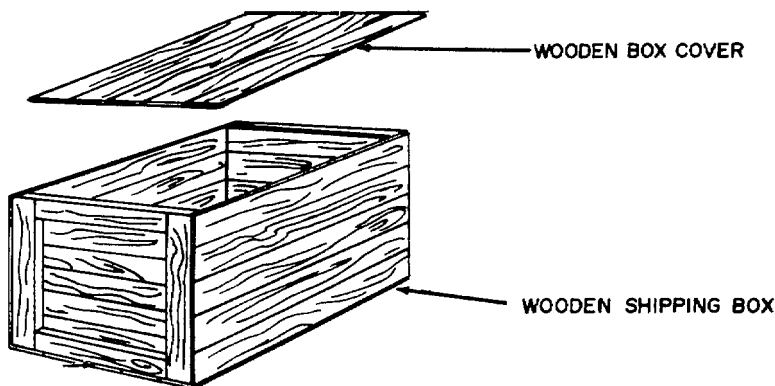

- Carefully lift corrugated box from wooden shipping box.
- Remove technical manuals and open corrugated box.

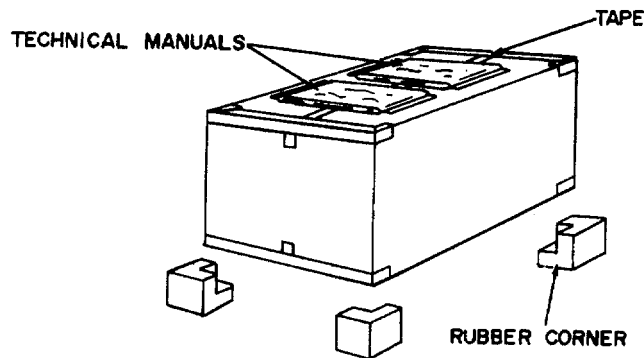

- Remove folded corrugated top liner.



- Carefully cut sealed barrier; remove equipment from box.
- Remove nuts and washers securing equipment to wooden shipping base.
- For TT-76A, B, C/GGC, cut tape securing chad bin accessory pack to transmitter distributor.
- Remove contents of tape storage bin kit, chad bin accessory pack and folded corrugated end liners.

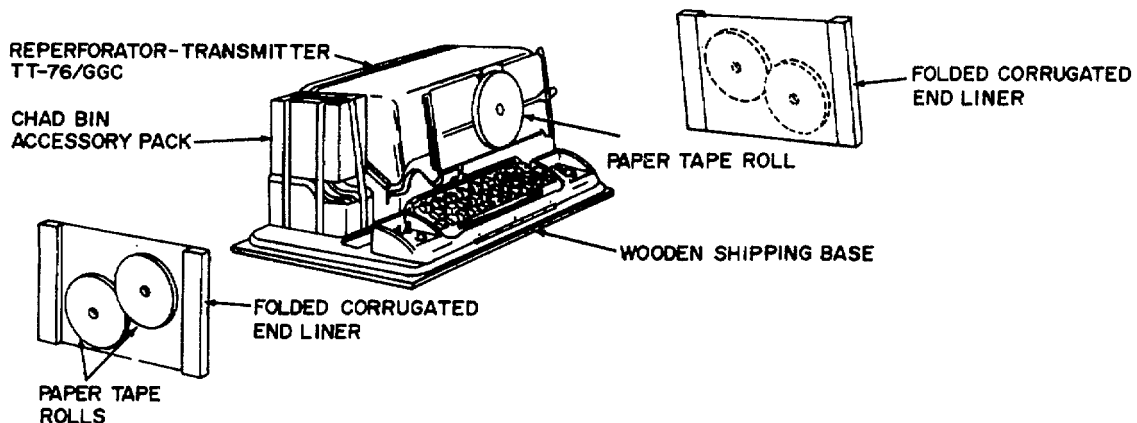

- For TT-761GGC, save wooden shipping base to use as a template for drilling mounting holes.

**2-5. CHECKING UNPACKED EQUIPMENT**

- Inspect equipment for any damage done during shipment. Report any damage on SF 364, Packaging Improvement Report.
- Compare equipment with the packing list to be sure it is complete. Report any differences according to instructions in TM 38-750.
- Check equipment near nomenclature plate for any Modification Work Order (MWO) numbers. They will appear ONLY if the equipment has been used or reconditioned. Current MWO's which apply to AN/GGC-3(\*) or AN/GGC-53(\*) are listed in DA Pam 310-1. Apply all URGENT MWO's. Schedule all NORMAL MWO's.

Section III. INSTALLATION INSTRUCTIONS

2-6. COMPONENT ASSEMBLY

Teletypewriter Set ANIGGC-3(\*)

- Place TT-76/GGC and table FN-52/GGC, on which it is mounted, on a flat surface. Lift front of FN-52/GGC until it is almost upright.
- Screw four table legs into leg. mounts on underside of table top.
- Press chad bin into holder under table and secure it with the wire retainer.
- To install paper tape and inking ribbon, refer to Operator's Manual TM 11-5815-238-10.

Teletypewriter Reperforator-Transmitter TT-76(\*)IGGC

- Use paper template (or wooden shipping base of TT-76IGGC) and mark top surface of table or shelf to be used to support unit.

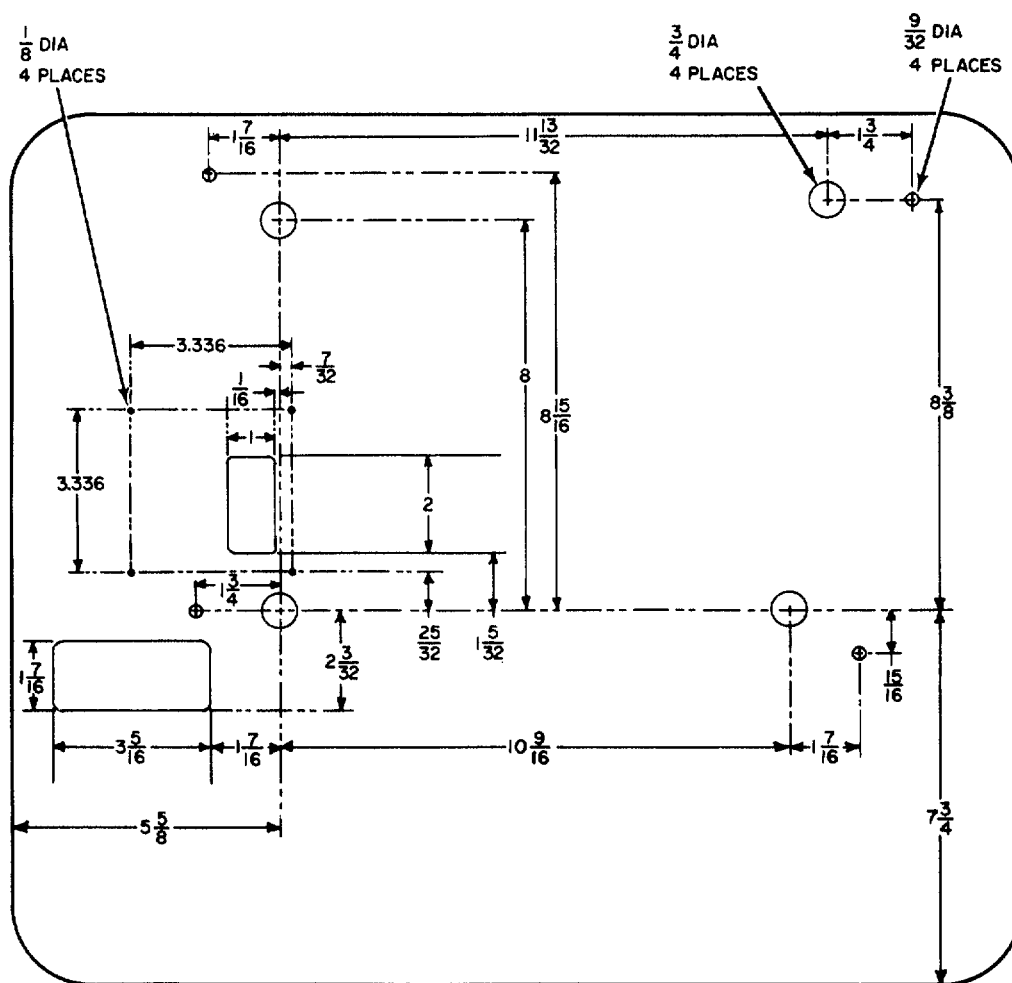

NOTE:

ALL DIMENSIONS ARE IN INCHES

- Cut openings in table or shelf for tape storage guide, chad tube, mounting bolts and chad bin mounting brackets.
- Secure TT-76(\*)/GGC to table or shelf with suitable mounting bolts. Install tape guide tape storage bin (TT-761GGC only) and chad tube retainer with hardware provided.
- To install paper tape and inking ribbon, refer to Operator's Manual TM 11-5815-238-10.



## 2-7. GROUND AND POWER CONNECTIONS

### NOTE

Make sure that AC plug is not plugged into AC outlet.

- Place MOTOR, LIGHT and POWER switches to OFF.
- Remove dust cover (see Operator's Manual TM 11-5815-238-10).
- Make sure 2-ampere fuses are installed in fuse holder on power supply and terminal unit and in spare fuse clips.

### NOTE

The TT-76IGGC uses one fuse in the power input circuit; the TT-76A, B, C/GGC use two fuses. All equipment is now supplied with 2-ampere fuses disregard any panel markings calling for 1.6-ampere fuses.

- Loosen clamping screw on power supply and terminal unit which locks power selector switch. Position switch to match supply voltage at installation site. Tighten clamping screw.

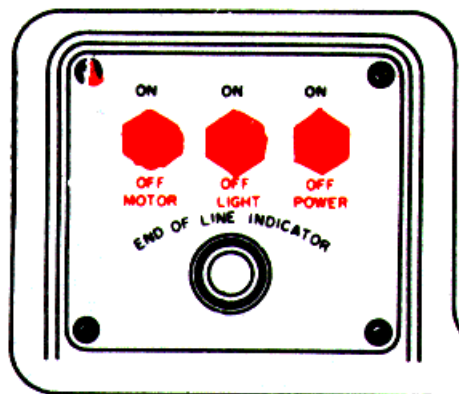
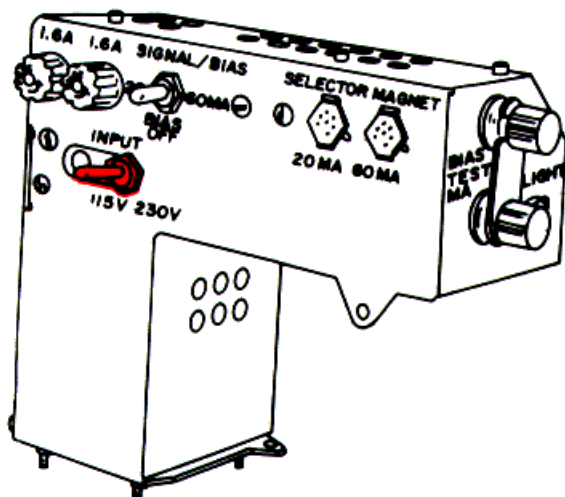

### NOTE

Figure of power supply and terminal unit illustrating power selector switch.

- Connect a wire from ground post behind transmitter-distributor to a cold water pipe, ground rod or similar low-resistance ground connection.
- In order to ground the power supply, connect the braided lead attached to TT-76/GGC power cord to a grounded portion of an ac outlet. For TT-76A, B, C/GGC, the power cord is fitted with a 3-pronged plug. When the plug is inserted into a receptacle, its third prong completes the ground connection. If the available ac outlet will not take a 3-pronged plug, remove screws holding third prong to plug; turn prong so it points in a direction opposite to the other two prongs. Disconnect ground lead attached to third prong and connect it to a grounded portion of ac outlet.
- Plug power cord into ac outlet.

2-8. FRICTION CLUTCHES

NOTE

Check felt washers in friction clutches for proper lubrication. See para. 2-21 for Instructions.

- (4) four clutches in use in the reperforator are: Keyboard-transmitter friction clutch Transmitter-distributor friction clutch Selector camshaft friction clutch Function shaft-friction clutch

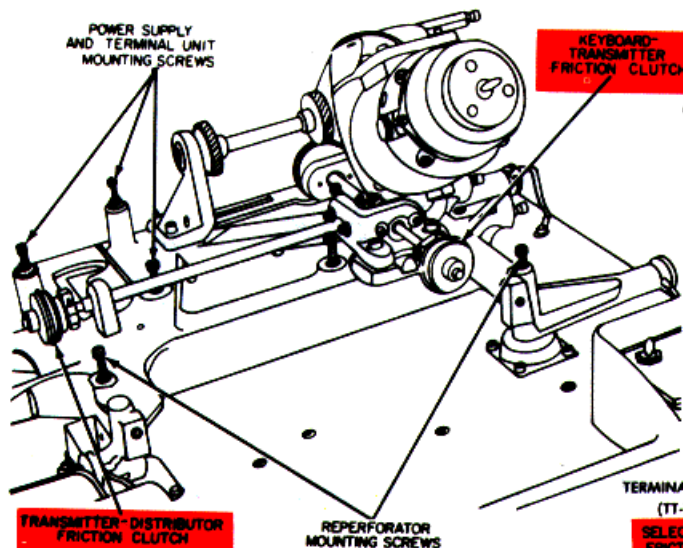

- They are factory adjusted and lubricated. They should be checked for proper lubrication prior to installation or service.

NOTE:

Check felt washers in friction clutches for proper lubrication. See para. 2-21 for instructions.

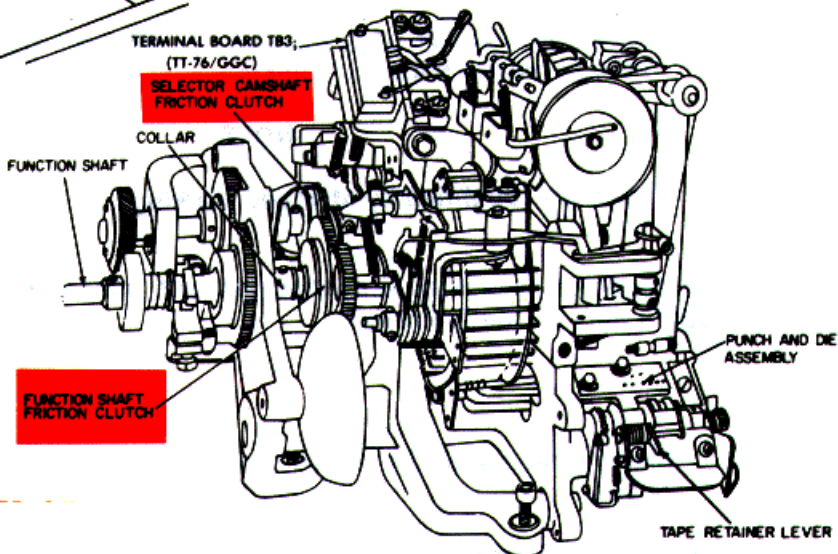

2-9. CHANGING OPERATION SPEED OF REPERFORATOR

NOTE

Refer to TM 11-5815-238-10 for nonsynchronous motor adjustment.

- Reperforator operating speed can be varied by changing the drive gear set. Gear set contains (1) worm gear on motor armature shaft and (2) the meshing driven gear.
- Reperforator is factory shipped with a 368.1 operation per minute (opm) 60 words per minute (wpm) gear set installed.

- **Gear set** for 600 opm (100 wpm) operation is mounted on the gearcase cover at right to reperforator.

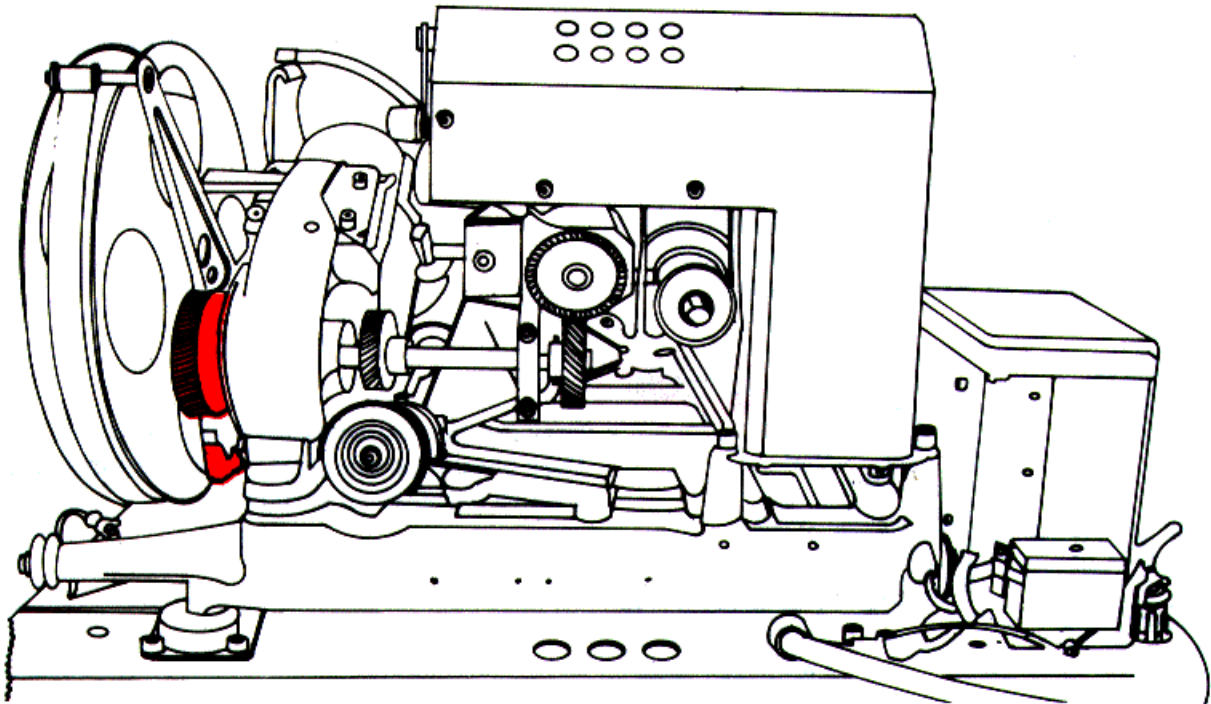

**NOTE**

If operation at 404 opm (66 wpm) or 460 opm (75 wpm) is desired, order through normal supply channels.

**NOTE**

Gears are identified by stamped markings.

- If It becomes necessary to change gear set, upon direction from supervisory personnel (SOP's etc.) do the following:

**CAUTION**

**Make certain MOTOR switch is OFF and power plug is removed from ac outlet.**

- Remove the tape reel.
- Loosen the motor.
- Remove the worm gear from the shaft of motor armature.
- Remove the driven gear from the power shaft (use a gear puller).
- Install worm gear\* on the shaft of the motor armature.
- Install driven gear\* on the power shaft.
- Reinstall motor.
- Reinstall tape reel.

\*matched set

**2-10. SIGNAL CIRCUIT CONNECTIONS FOR TT-76(\*)IGGC.**

Teletypewriter Set ANIGGC-3(\*) or Teletypewriter Reperforator-Transmitter TT-76(\*)IGGC provides dc current for operation of internal local circuits ONLY. Current for external signal line circuits must be supplied by a telegraph switchboard, line unit, Telegraph Terminal TH-5/TG or other external source.

Signal circuits within reperforator-transmitter are controlled by SELECTOR switch located to right of keyboard. Signal circuits of transmitter-distributor, keyboard-transmitter and reperforator are terminated in standard 2-conductor jack plugs. This permits reperforator-transmitter to operate in various sending and receiving combinations.

**Wiring Options**

- **NEUTRAL OPERATION:** For TT-76/GGC, the selector magnet is wired for 20-mA neutral operation when reperforator is delivered by manufacturer. Wiring options for both 20mA and 60-mA neutral operation of selector magnet are shown in figure below.

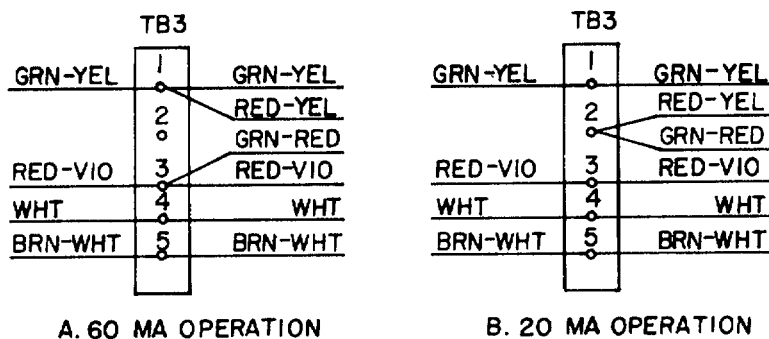

For TT-76A, B, CIGGC, set SIGNAL/BIAS switch on power supply and terminal unit to 20-MA or 60-MA position, whichever is applicable. Insert plug from selector magnet cable into 20-MA or 60-MA socket, whichever is applicable.

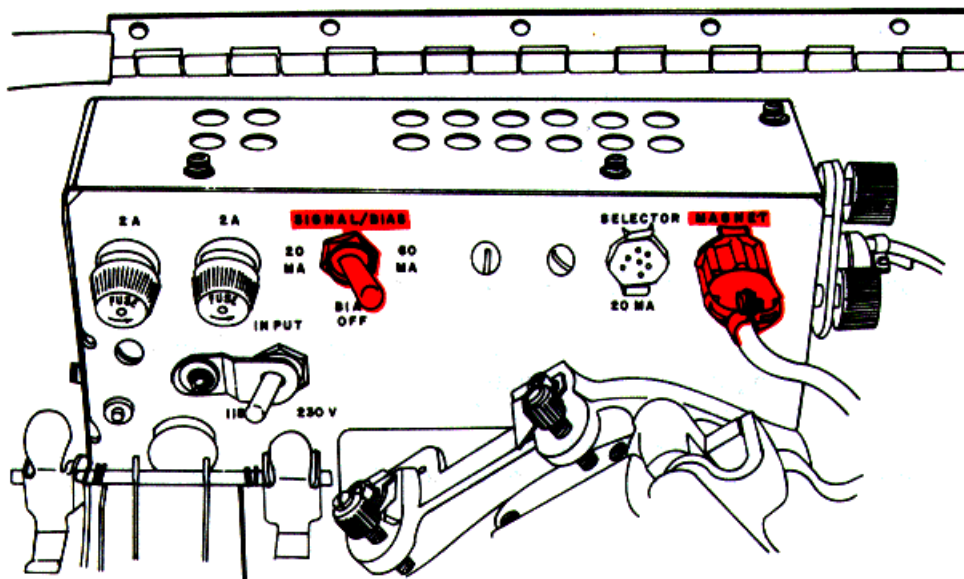

- **POLAR OPERATION:** Adapt the reperforator for polar operation according to instructions given below:

Polar Receive: For TT-76/GGC, remove and tape separately BRN-WHT wire from terminal 5 and WHT wire from terminal 4 of terminal block TB3. For TT-76A, B, CIGGC, set 20-BIAS/OFF-60 switch to BIAS/OFF and insert plug from selector magnet cable into 60-MA socket.

**NOTE**

The following items are not supplied with the reperforator-transmitter: 220ohm wire wound resistors, 7,000-ohm center tapped resistor (voltage divider) and a power source capable of supplying 120 volts dc at 220 mA.

Polar Send: The transmitter-distributor and keyboard-transmitter can be changed to send polar signals by making wire changes, at terminal block TB2 of TT76/GGC or TB1 of TT-76A, B, CIGGC and by adding two 220-ohm wire wound resistors, one 7,000-ohm center tapped resistor (voltage divider) and a power source capable of supplying 120 volts dc at 220 mA to the circuit.

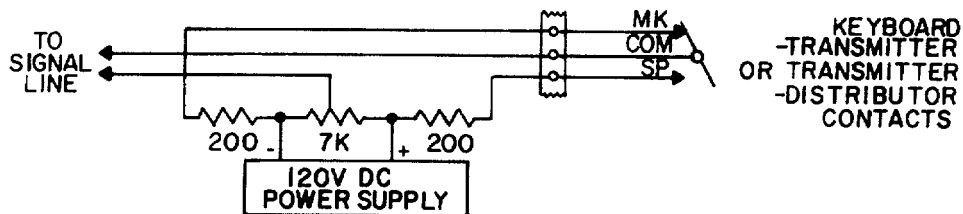

- To make wire changes on transmitter-distributor:
  - Remove gray plug and cord from terminals 6 and 7 of terminal block.
  - Connect marking battery to terminal 7.
  - Connect spacing battery to terminal 8..
  - Connect one signal line wire to terminal 6.
  - Connect other signal line wire to midpoint of 7,000-ohm resistor.
- To make wire changes on keyboard-transmitter:
  - Remove black plug and cord from terminals 1 and 2 of terminal block.
  - Connect marking battery to terminal 1.
  - Connect spacing battery to terminal 3.
  - Connect one signal line wire to terminal 2.
  - Connect other signal line wire to midpoint of 7,000-ohm resistor.

The reperforator-transmitter can be connected for the five different operating combinations listed below. The operating capabilities for each combination are described in Operator's Manual TM 11-5815-238-10.

**SEND ONLY AND LOCAL PREPARATION OF TAPE**

**NOTE**

The TT-699(\*)IGGC and some specially installed TT-76(\*)/GGC's do not have red, black or gray plugs.

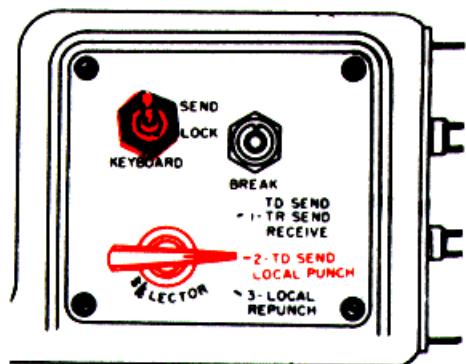

- Set SELECTOR switch to position 2 (TD SEND LOCAL PUNCH).
- Insert gray plug of transmitter/distributor in SEND jack of Teletype terminal TH-5/TG or similar device.
- Do not use red or black plugs.

**DUPLEX OPERATION**

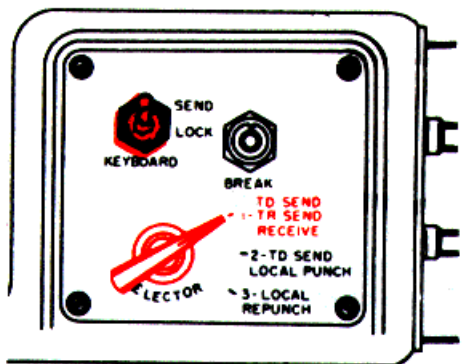

- Set SELECTOR switch to position 1 (TD SEND TR SEND RECEIVE).
- Insert red plug of reperforator into REC jack of Teletype terminal TH-5/TG or similar device of one line.
- Insert black and gray plugs into SEND jacks of line terminating device of second line.

**HALF DUPLEX OPERATION**

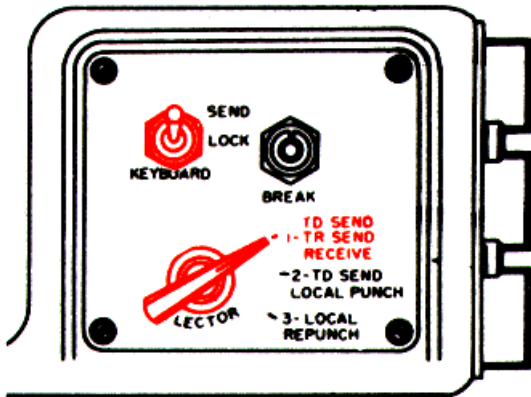

- Set SELECTOR switch to position 1 (TD SEND TR SEND RECEIVE).
- Insert red, black and gray plugs into SEND and REC jacks of Teletype terminal TH-5/TG or similar device.

**ONE-WAY OPERATION (RECEIVE ONLY)**

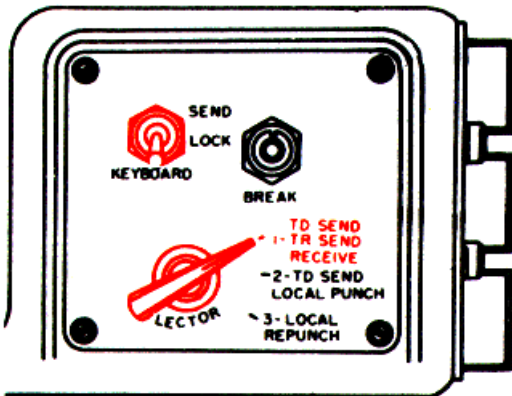

- Set Keyboard switch in the lock position.
- Set SELECTOR switch to position 1 (TD SEND TR SEND RECEIVE).
- Insert red plug into REC jack of Teletype terminal TH-5/TG or similar device.
- Do not use black or gray plugs.

**HALF DUPLEX AND SEND ONLY**

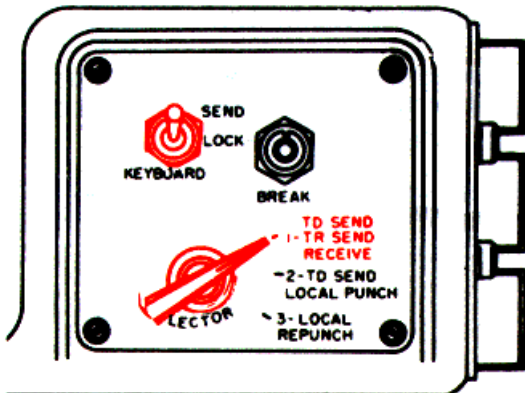

- Set SELECTOR switch to position 1 (TD SEND TR SEND RECEIVE).
- Insert red and black plugs in the REC and SEND jacks of the halfduplex line.
- Insert gray plug into SEND jack of send only line.

- Make all adjustments listed in paragraph 2-24 before turning this equipment over to the operator.



## 2-11. SIGNAL CIRCUIT CONNECTIONS FOR TT-699(\*)IGGC

Teletypewriter Set AN/GGC-53(\*) or Teletypewriter Reperforator-Transmitter TT-699(\*)IGGC does not need an external power source.

Signal circuits within reperforator-transmitter are controlled by a SELECTOR switch located to right of keyboard. Signal circuits of transmitter-distributor, keyboard transmitter and reperforator can be connected to external signal lines at terminals 5, 6, 8 and 9-of A1TB-1. This permits reperforator-transmitter to operate in various sending and receiving operations.

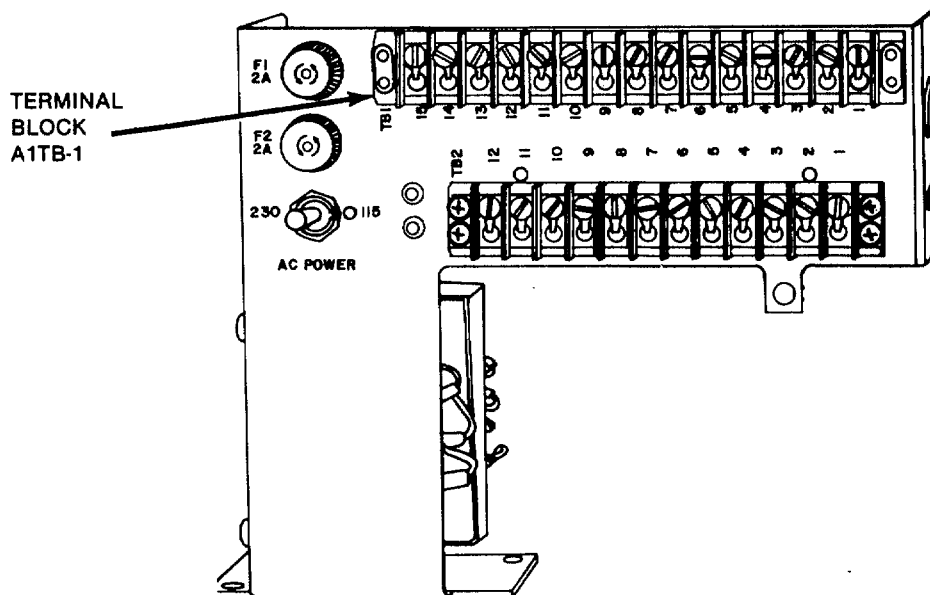

### a. WIRING

Teletypewriter Reperforator-Transmitter TT-699(\*)/GGC can only perform with a 6 volt polar operation; no internal wiring changes are required.

### b. INSTALLATION CONNECTIONS

For all polar operations, make sure line connections are the same as those shown below.

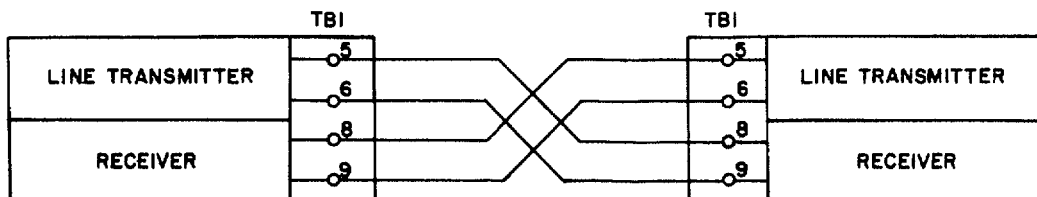



**DUPLEX OPERATION**

- Set SELECTOR switch to position 1 (TD SEND TR SEND RECEIVE).

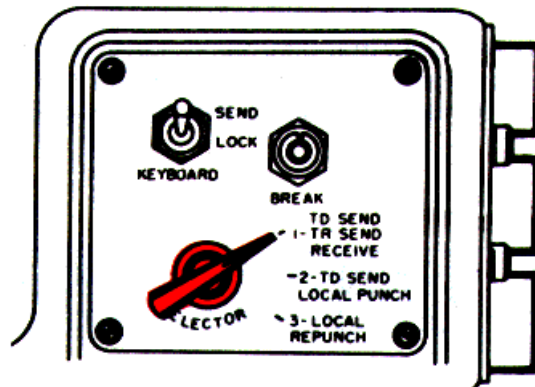

**SEND ONLY AND LOCAL PREPARATION OF TAPE**

- Set SELECTOR switch to position 2 (TD SEND LOCAL PUNCH).

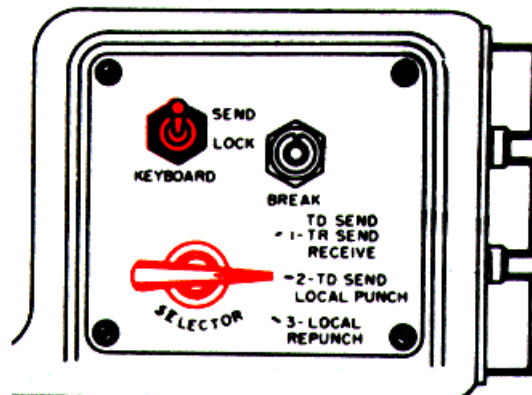

**LOCAL REPUNCH**

- Set SELECTOR switch to position 3 (LOCAL PUNCH).

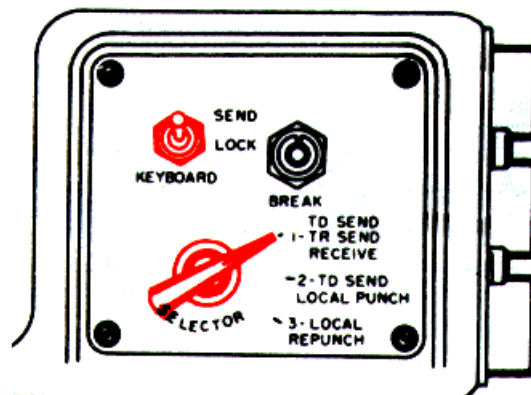

## Section IV. PREVENTIVE MAINTENANCE CHECKS AND SERVICES (PMCS)

### 2-12. GENERAL

The following information is for MONTHLY preventive maintenance checks and services (PMCS) of Teletypewriter Sets ANIGGC-3(\*) and ANIGGC-53(\*), and Teletypewriter Reperator Transmitters TT-76(\*)/GGC and TT-699(\*)/IGGC. Monthly PMCS should be performed every 30 calendar days of 8 hour-per-day operation. If the equipment is operated 16 hours-per-day, check it at 15-day intervals. Monthly PMCS should be done if the ANIGGC-3(\*), ANIGGC-53(\*), TT-76(\*)/GGC, or TT-699(\*)/GGC is in standby (ready for immediate operation) condition, but is not needed if the equipment is in limited storage. Maintenance forms and records to be used and maintained on this equipment are specified in TM 38-750. Perform all checks and services in sequence listed in Table 2-1.

- a. Tools, Test Equipment and Material needed for Organizational level PMCS.
- All the tools you need for PMCS on the AN/GGC-3(\*), AN/GGC-53(\*), TT-76(\*)/IGGC or TT-699(\*) are in Tool Equipment TE-50B. For expendable supplies and materials, refer to Appendix C.
    - Required material: Lubricating oil  
Cleaning cloth  
Cleaning solvent (SD)  
Trichlorotrifluoroethane



**Fumes of TRICHLOROTRIFLUOROETHANE are poisonous. Provide adequate ventilation whenever you use TRICHLOROTRIFLUOROETHANE. Do not use solvent near heat or open flame. TRICHLOROTRIFLUOROETHANE will not burn, but heat changes the gas into poisonous, irritating fumes. DO NOT breathe the fumes or vapors TRICHLOROTRIFLUOROETHANE dissolves natural skin oils. DO NOT get the solvent on your skin. Use gloves, sleeves and an apron which the solvent cannot penetrate. If the solvent is taken internally, see a doctor.**

- b. PMCS Table (Table 2-1).

### ROUTINE SERVICES

Routine services are a collection of checks and observations performed by the operator at all times. Routine services are not listed in the preventive maintenance checks and services table, in order to separate the nonoperational from the operational services. You should perform the following routines as necessary.

- Clean
- Dust
- Wash
- Check for cut or frayed cables
- Check for dented, bent, or broken components
- Check for rusting
- Check controls for smooth operation
- Check for loose nuts, bolts, and connectors
- Check for completeness of equipment

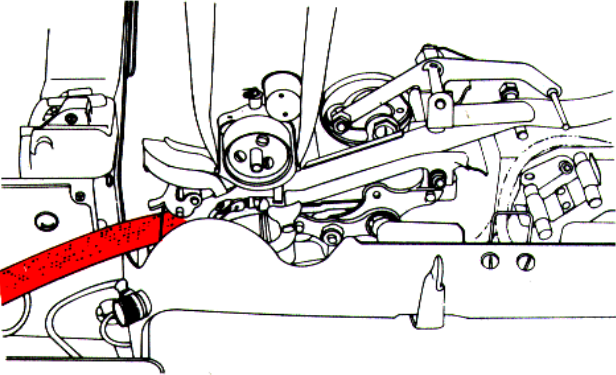

TABLE 2-1. MONTHLY PMCS TABLE

ITEM NO.	ITEM TO BE INSPECTED	PROCEDURES
1	Tape perforations	<p>Check tape perforations for tearing, clean punching and drifting. Punched feed holes in the message tape should be spaced evenly, 10 holes per inch. Use tape gauge in Tool Kit TE-50B to check this requirement. If incorrect, higher category of maintenance is required.</p> 
2	Lubrication	<p>Check to see that lubrication of steel mounting screws (in aluminum or magnesium castings), and felt washers located on keyboard shaft, selector cam shaft, function shaft and transmitter-distributor shaft have been performed according to schedule established by local standard operating procedures. See paragraph 2-21.</p>
3	Publications	<p>Check DA Pam 310-1 for new publications and new applicable MWO's. DA Pam 310-7 for any new applicable MWO's.</p> <p style="text-align: center;"><b>NOTE</b></p> <p>Operational checks are to be conducted in accordance with local command Standard Operating Procedures (SOP).</p>
4	Operational Check	<p>Check the AN/GGC-3(*), ANIGGC-53(*), TT-76(*)/GGC, or TT-699(*)IGGC by operating it (refer to TM 11-5815-238-10).</p> <p style="text-align: center;"><b>NOTE</b></p> <p>Check to insure that operator maintenance has been performed.</p>

## Section V. TROUBLESHOOTING

### 2-13. GENERAL

Troubleshooting at the Organizational Maintenance level requires you to locate any trouble as quickly as possible.

Once trouble is located, repair or replace the part if you are authorized to do so or determine if a higher category of maintenance is required. Repairs by Organizational Maintenance are limited to tools, test equipment and replacement parts allocated to that level by the Maintenance Allocation Chart (MAC) located in Appendix B of this manual.

### 2-14. VISUAL INSPECTION

- Equipment failure or improper operation is usually caused by one or more of the visible faults listed below:
  1. Improperly connected power cord.
  2. Burned out fuse in power supply and terminal unit.
  3. Worn, broken, burned out or disconnected cord or plug.
  4. Wires broken by too much vibration.
  5. Loose ground connection, particularly in dc systems using a simplex line.
  6. Worn or, damaged mechanical part.
  7. Power selector switch not set to match ac power.
  8. Inadequate supply of paper tape, or improper positioning of tape through guides, under type wheel and through punch and die assembly.
  9. Improper positioning of inking ribbon around spools and rollers or not passed through guide slots.
  10. Power switch not turned ON.
  
- Visually check as much of the line system as possible for obvious trouble, especially lines not connected into proper facilities for type of operation desired.

#### NOTE

**Before using Troubleshooting Table (Table 2-2), check your work order and talk to the Operator, if possible, for a description of symptoms if trouble occurred while equipment was in operation.**

### 2-15. TROUBLESHOOTING TABLE (Table 2-2)

Table 2-2 lists common problems that may occur during operation or maintenance of AN/GGC-3(\*) or AN/GGC-53(\*).

Follow these steps to use Table 2-2:

- Find the problem under MALFUNCTION.
- Check for possible causes of the problem under TEST OR INSPECTION.
- Use the procedures under CORRECTIVE ACTION to correct the problem.

**NOTE**

The procedures in Table 2-2 assume that the teletypewriter is connected to a signal line or the local test circuit (see para 2-11), that a good fuse is properly inserted in the fuse holder and that paper tape has been properly loaded in the teletypewriter.

- This manual cannot list all troubles that may occur, nor everything to check, nor all possible procedures to correct troubles listed. If trouble is not listed in Table 2-2 or is not corrected by the procedures under CORRECTIVE ACTION, notify your supervisor or next higher level of maintenance.
- Set KEYBOARD switch to SEND position.
- Set SELECTOR switch to position 3 (LOCAL REPUNCH).

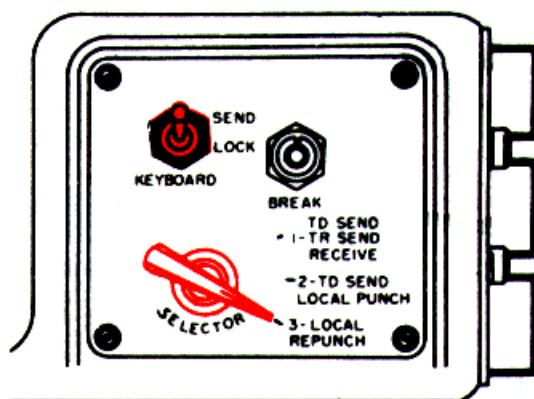

TT-76(\*)/GGC teletypewriter transmitter contacts are now placed in series with the selector magnet and a local dc supply. TT-699(\*)/GGC teletypewriter contacts are now placed in series with each other and the input from the line transmitter module. The local machine reperforator can now be operated with signals received directly from transmitter-distributor or key board transmitter.

**NOTE**

If the trouble still exists after Troubleshooting, check for it in the line circuit or at the distant teletypewriter.

Table 2-2. TROUBLESHOOTING

**MALFUNCTION**  
**TEST OR INSPECTION**  
**CORRECTIVE ACTION**

1. Copy light does not light up.

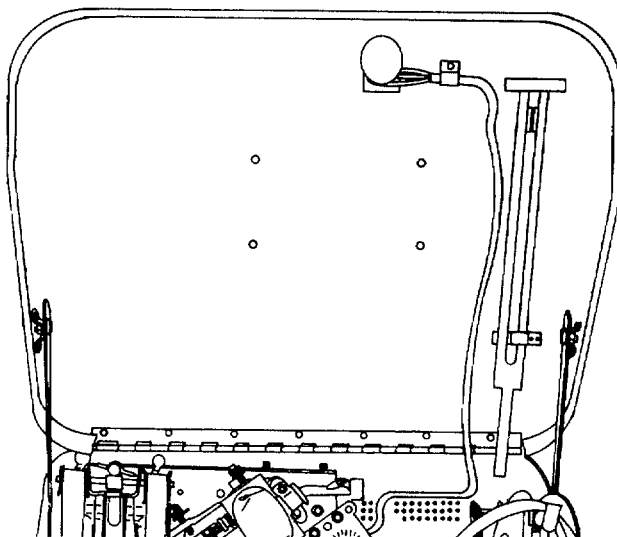

**NOTE**

POWER switch ON for all procedures. Lift keyboard guard assembly to check connections. (all models except TT-76/GGC, TT-699/GGC which are secured to base plate by machine screws and washers)

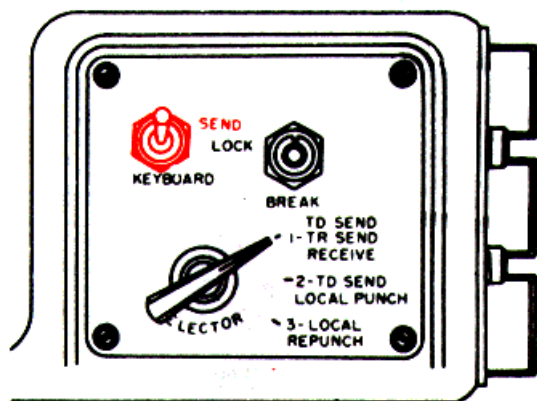

Step 1. Be sure unit is plugged in.

Step 2. Be sure **LIGHT switch** is set to **ON**.

Step 3. If LIGHT switch is set to ON, check lamp for burned out bulb and be sure switch is free from binding.

Step 4. Check rear of light switch for loose, frayed or broken wires.

If light bulb is in working order, higher category of maintenance required.

Table 2-2. TROUBLESHOOTING - Continued

**MALFUNCTION**  
**TEST OR INSPECTION**  
**CORRECTIVE ACTION**

**2. Motor does not start.**

Step 1. Check for blown fuses, broken wires, defective power switch.

Replace blown fuses, report all other defects to next higher maintenance level.

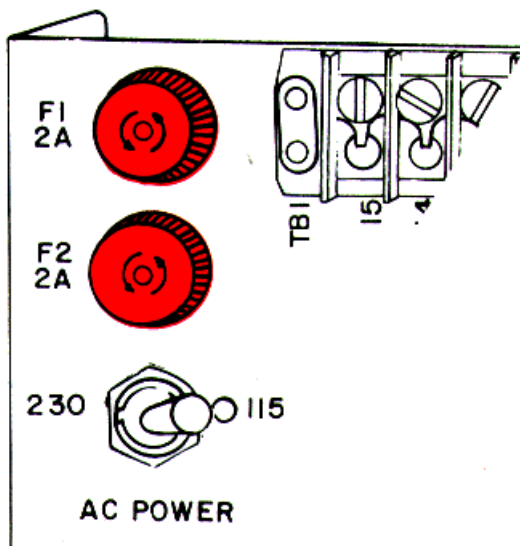

Step 2. Use Multimeter ANIUSM-451 to check ac wall socket for 115 volts ac or 230 volts ac input voltage.

Step 3. Check ac cable for breaks.

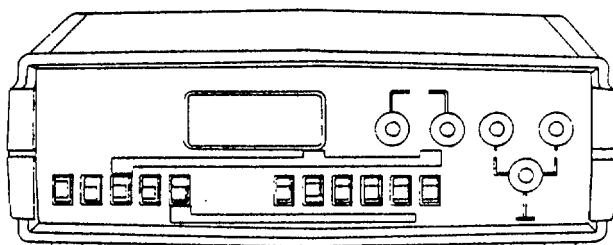

**Multimeter AN/USM-451**

If these steps do not correct problems, higher category of maintenance is required.

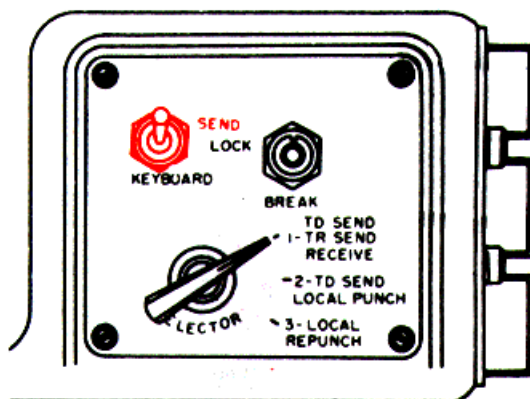

Table 2-2. TROUBLESHOOTING - Continued

**MALFUNCTION  
TEST OR INSPECTION  
CORRECTIVE ACTION**

**3. Keyboard-transmitter will not transmit.**

Be sure KEYBOARD switch is set to SEND.



If switch is set to SEND and unit does not respond higher category of maintenance is required.

**4. Teletypewriter does not give correct copy at desired range.**

Step 1. Loosen and swing up shorting bar, and connect Multimeter AN/USM-451 between two terminals of BIAS TEST MA.

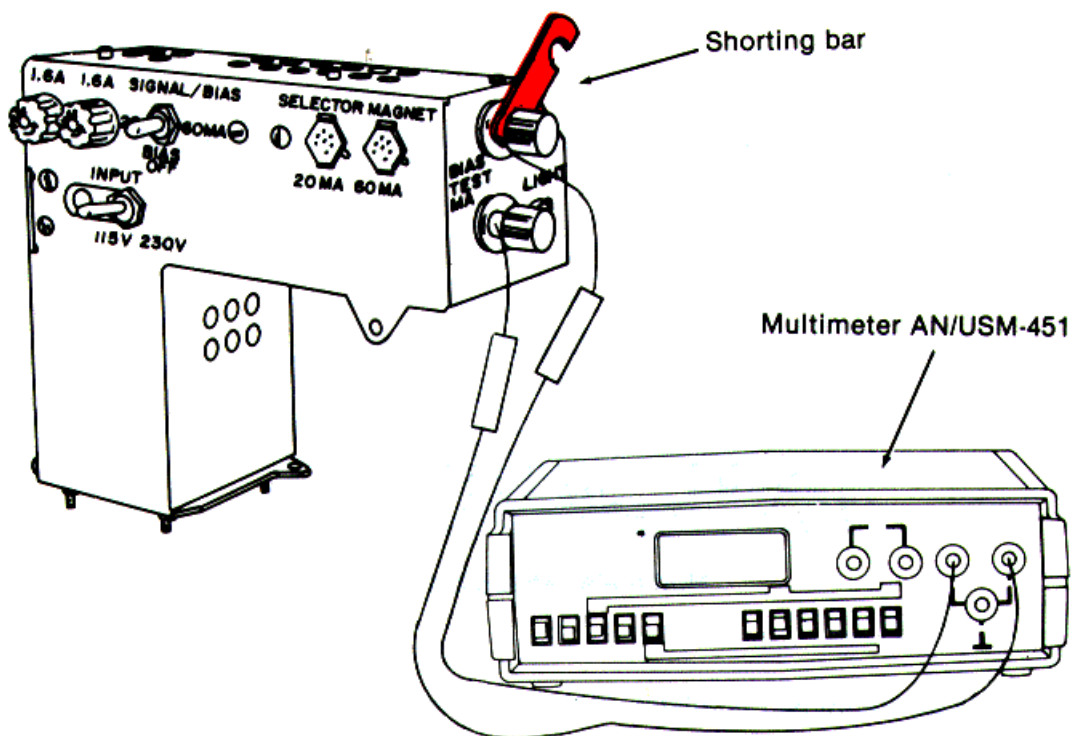

Table 2-2. TROUBLESHOOTING- Continued

**MALFUNCTION  
TEST OR INSPECTION  
CORRECTIVE ACTION**

Step 2. Be sure SIGNAL BIAS switch in 20-MA position to check for 20 mA reading and SELECTOR MAGNET plug is in 20 mA position. Change to 60-MA positions and take 60 mA readings.

Step 3. Current in bias circuit should read 12.25 mA if selector plug is in 60-MA jack or 8.75 mA if selector plug is in 20-MA jack. Refer to TM 11-5815-238-10.

Adjust bias. Refer to TM 11-5815-238-10 (TT-76/GGC) or paragraph 2-24, this TM (TT-76A, B or C/GGC).

If meter still does not equal the values given in Step 3. higher category of maintenance required.

**5. Reperforator prints errors or scrambles letters and functions.**

Be sure rangefinder dial is properly set.

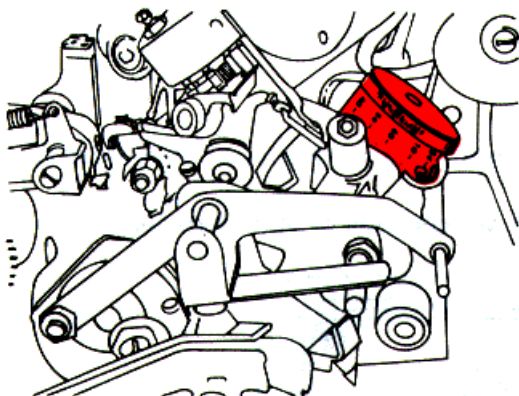

Adjust rangefinder dial between maximum and minimum good copy positions. Refer to TM 11: 5815-238-10.

**CAUTION**

Do not change position of rangefinder dial while teletypewriter is OFF.

**6. Wrong characters are printed at either distant or local teletypewriter.**

Be sure motor is operating at correct speed of 3600 revolutions per minute (rpm).

Adjust motor speed to 3600 rpm. (See TM 11-5815-238-10)

Paper tape does not feed properly when SPACE BAR and REPEAT key are pressed.

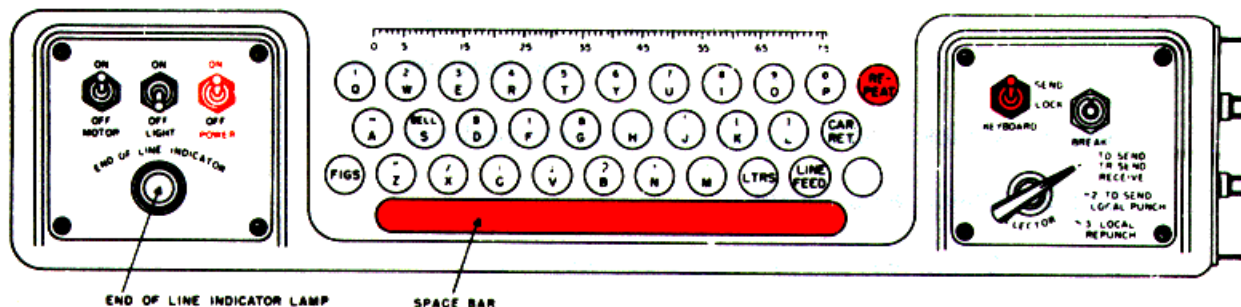
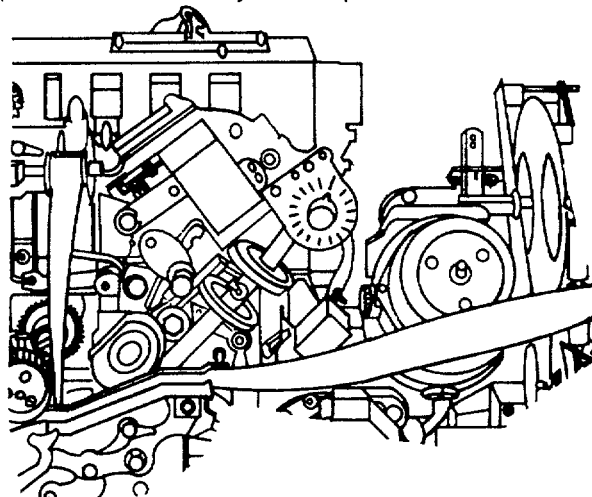

Table 2-2. TROUBLESHOOTING - Continued

**MALFUNCTION**  
**TEST OR INSPECTION**  
**CORRECTIVE ACTION**

Step 1. Check for bent reel.

Step 2. Be sure paper feeds smoothly into tape chute.



If problem is not corrected, higher category of maintenance required.

**7. END-OF-LINE INDICATOR lamp does not light on operation of 66th character.**

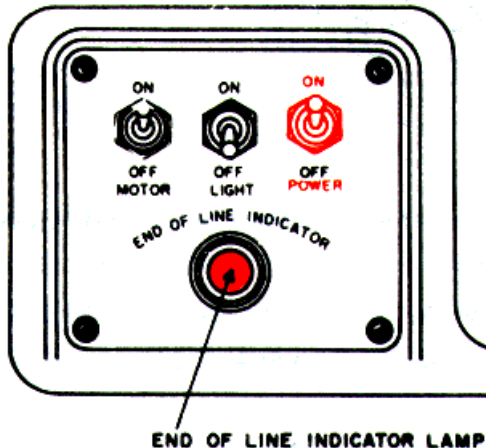

Step 1. Check lamp for burned out bulb and contacts.

Step 2. Check lamp socket.

Step 3. Check rear of switch wire connections. Replace lamp if necessary.

Table 2-2. TROUBLESHOOTING - Continued

**MALFUNCTION**  
**TEST OR INSPECTION**  
**CORRECTIVE ACTION**

8. END-OF-LINE INDICATOR lamp does not go out when CAR. RET. key is pressed.

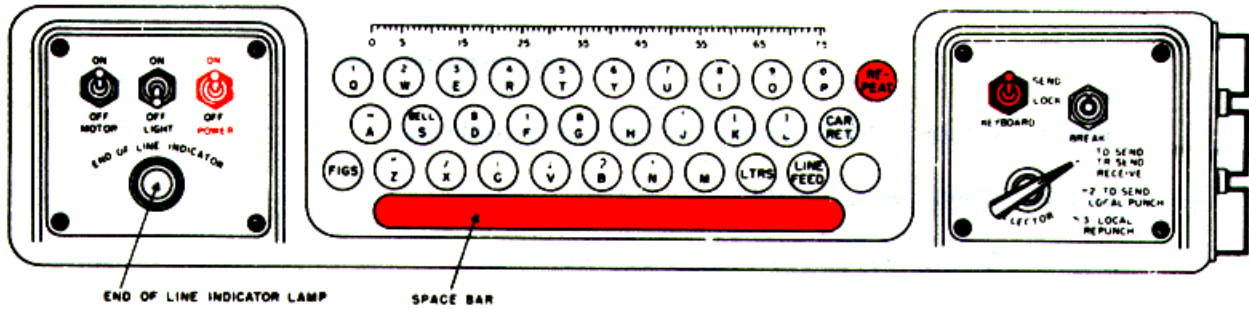

Check character counter freely returns to left side after CAR RET key is pressed.

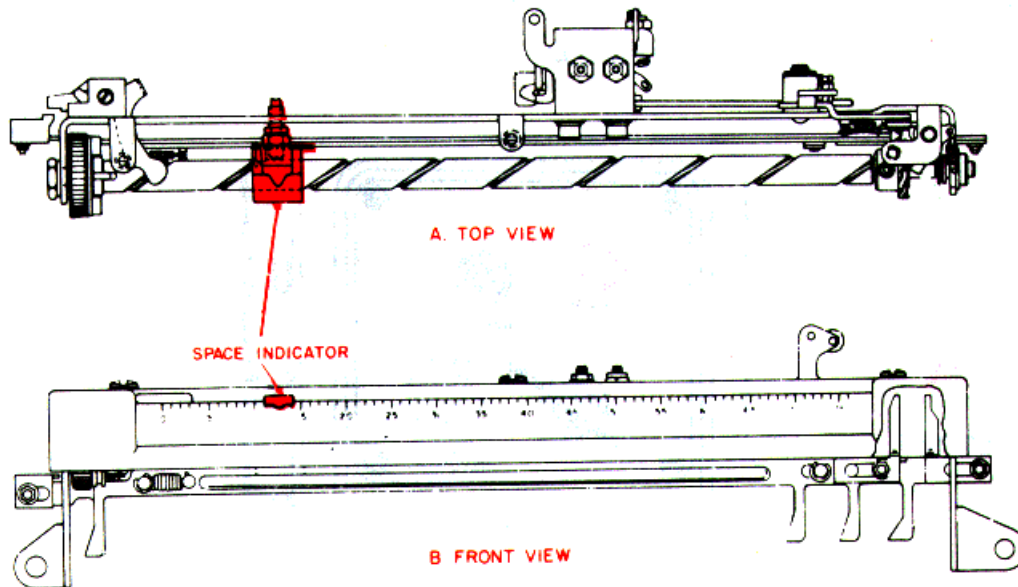

If it does not freely return, higher category of maintenance required.

Table 2-2. TROUBLESHOOTING-Continued

**MALFUNCTION**  
**TEST OR INSPECTION**  
**CORRECTIVE ACTION**

9. When any character key and REPEAT key are pressed at same time selected character does not repeat.

Step 1. Check **REPEAT key lever, repeat lever and repeat blocking lever** for free movement.

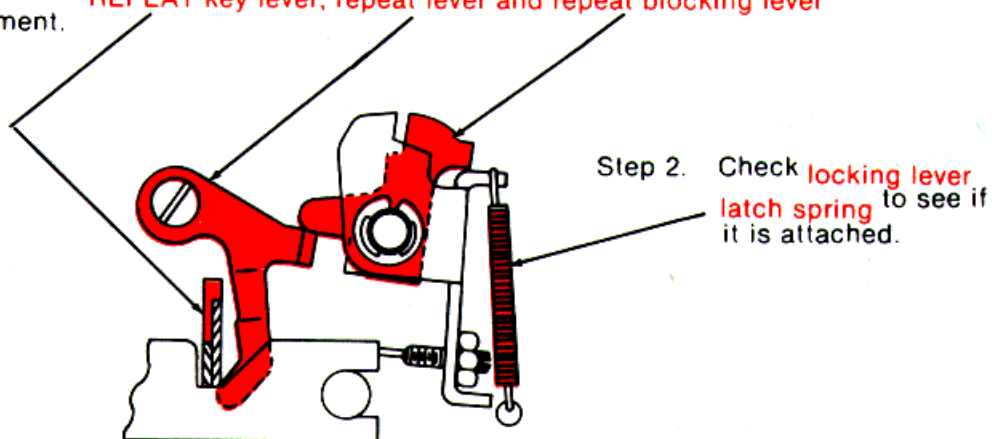

If problem is not corrected, higher category of maintenance required.

10. Signal line does not open when BREAK key is pressed.

Step 1. Check operation of BREAK key.

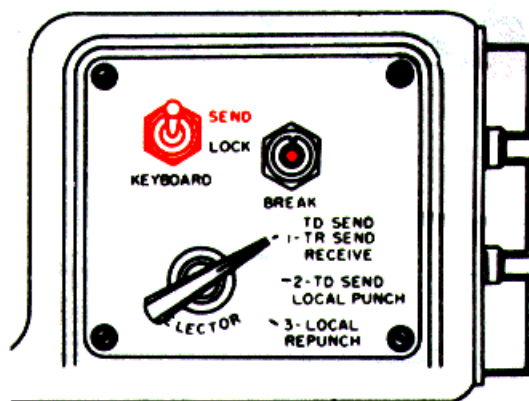

**CAUTION**  
 Turn off equipment.

Step 2. Lift cover, check rear of switch.

If problem is not corrected, higher category of maintenance required.

Table 2-2. TROUBLESHOOTING-Continued

**MALFUNCTION**  
**TEST OR INSPECTION**  
**CORRECTIVE ACTION**

**11. Improper or no printing.**

Step 1. Type wheel is projected and restored for each operation, and shifts to figure positions properly.

Step 2. Check for proper ribbon feed.

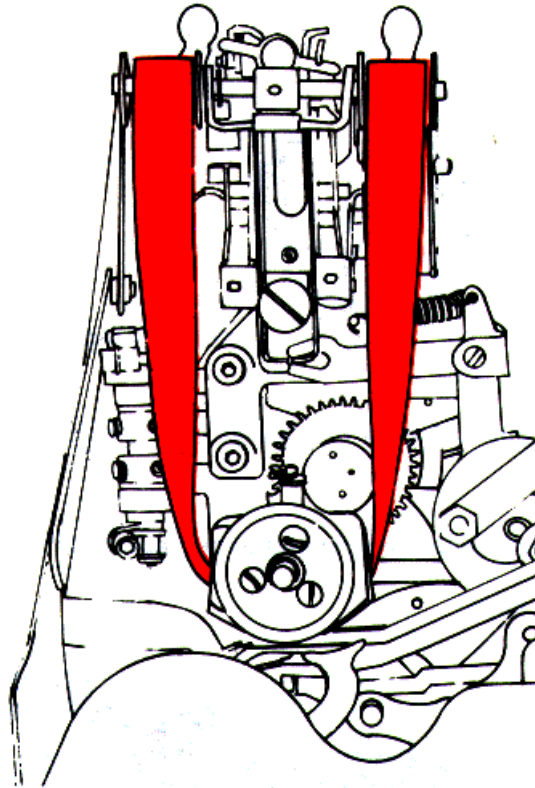

If problem is not corrected, higher category maintenance required.

Table 2-2. TROUBLESHOOTING - Continued

**MALFUNCTION**  
**TEST OR INSPECTION**  
**CORRECTIVE ACTION**

**12. Inking ribbon does not advance as characters are typed.**

Check ribbon for proper installation.

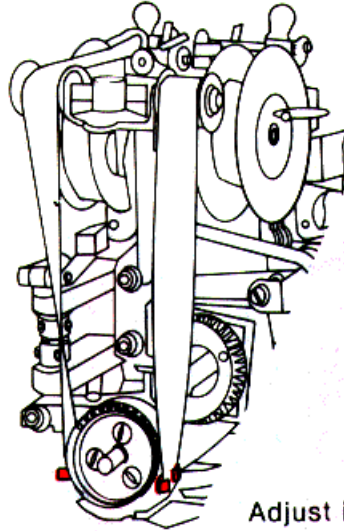

Adjust inking ribbon through guides.

If problem is not corrected, higher category of maintenance required.

**13. Code or feed holes do not punch properly and paper tape is cut or torn.**

Check for proper tape feed.

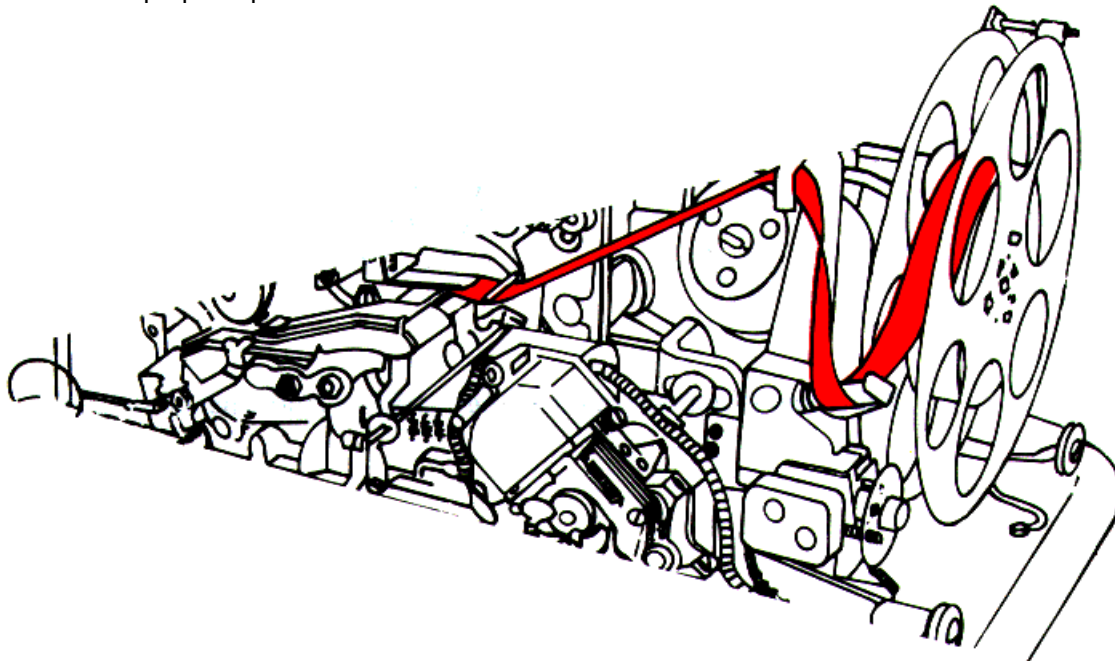

Adjust paper tape through guides. If problem is not corrected, higher category of maintenance required.



## Section VI. MAINTENANCE PROCEDURES

### 2-17. GENERAL

- Organizational Maintenance of Teletypewriter Reperforator-Transmitters TT-76(\*)/GGC and TT-699(\*)/GGC is limited to:
  1. INSPECTION
    - Installed items
  2. CLEANING
    - Internal mechanical assemblies
    - Electrical contact surfaces
  3. TESTING
    - AC input voltage
  4. PAINTING
    - Metal Surfaces
  5. LUBRICATING
    - Steel setscrews in aluminum and magnesium castings.
    - Felt washers (friction clutches).
  6. ADJUSTMENT
    - Motor speed
    - Rangefinder dial
    - Bias potentiometer (TT-76/GGC ONLY)

#### NOTE

All procedures are the same for TT-76(\*)/GGC as for TT-699(\*)/GGC.

### 2-18. TOOLS, TEST EQUIPMENT AND MATERIAL REQUIRED OF ORGANIZATIONAL MAINTENANCE.

- All tools you will need for maintenance on ANIGGC-3(\*) and AN/GGC-53(\*) are in Tool Equipment, TE-50-B.
- Required test equipment: Multimeter AN/USM-451.
- Required material: Cleaning solvent (SD)  
Trichlorotrifluoroethane (NSN 6850-00-105-3084)
- Lubricant: Oil (NSN 9150-00-223-4129).

#### WARNING

Fumes of TRICHLOROTRIFLUOROETHANE are poisonous. Provide adequate ventilation whenever you use TRICHLOROTRIFLUOROETHANE. Do not use solvent near heat or open flame. TRICHLOROTRIFLUOROETHANE will not burn, but heat changes the gas into poisonous, irritating fumes. DO NOT breathe the fumes or vapors TRICHLOROTRIFLUOROETHANE dissolves natural skin oils. DO NOT get the solvent on your skin. Use gloves, sleeves and an apron which the solvent cannot penetrate. If the solvent is taken internally, see a doctor.

### 2-19. INSPECTION

Be sure all equipment is properly installed. Check for proper positioning and tightening of all nuts, bolts and washers.



**NOTE**

In order to perform the following cleaning procedures, follow the instructions for removal and replacement of dust covers in Operator's Manual TM 11-5815-238-10.

**2-20. CLEANING****a. Internal Mechanical Assemblies.**

Use a clean, lint-free cloth dampened (not wet) with cleaning solvent (SD) to remove dust or dirt. Wipe dry.

**b. Electrical Contact Surfaces.****WARNING**

Fumes of TRICHLOROTRIFLUOROETHANE are poisonous. Provide adequate ventilation whenever you use TRICHLOROTRIFLUOROETHANE. Do not use solvent near heat or open flame. TRICHLOROTRIFLUOROETHANE will not burn, but heat changes the gas into poisonous, irritating fumes. DO NOT breathe the fumes or vapors TRICHLOROTRIFLUOROETHANE dissolves natural skin oils. DO NOT get the solvent on your skin. Use gloves, sleeves and an apron which the solvent cannot penetrate. If the solvent is taken internally, see a doctor.

Use a clean, lint-free cloth or a brush dampened (not wet) with Trichlorotrifluoroethane to remove dust and dirt from electrical contacts. Wipe dry with another clean, lint-free cloth.

**2-21. LUBRICATING****a. Friction Clutches (4) see paragraph 2-8.**

- Check for proper lubrication **prior to installation** placing into service.
- If lubrication is required, apply 10 to 15 drops of oil (NSN 9150-00-223-4129) around outer edge of each felt washer.
- Wipe off excess with clean cloth.

**b. Steel Mounting Screws (magnesium and aluminum casting)**

- Lightly oil.

**2-22. TESTING**

Use Multimeter ANIUSM-451 to test dc voltage input of TT-76(\*)/GGC or TT-699(\*)/GGC; it should be 115 vac or 230 vac.

**2-23. PAINTING**

Remove rust and corrosion from metal surfaces by lightly sanding with fine sandpaper. Brush two thin coats of the proper paint on bare metal to protect it from further corrosion. Refer to applicable procedures in TB 43-0118.

## 2-24. ADJUSTMENTS

Motor speed and Rangefinder adjustments for all models of teletypewriter-reperforator, and Bias adjustment for TT-76/GGC are found in TM 11-5815-238-10.

### NOTE

**If reperforator is equipped with a synchronous motor, motor speed adjustment not required.**

Bias Potentiometer Adjustment for TT-76AIGGC and later models

### NOTE

**Make the following adjustment only when equipment is operating in a neutral circuit, since bias windings are not used for polar operation.**

- Set keyboard SEND LOCK switch to the SEND position and the SELECTOR SWITCH to position 3 (LOCAL REPUNCH).
- Shut off equipment - switches.
- Loosen the strap across the BIAS TEST MA terminal on the power supply and terminal unit and move to up position.
- Power switch on position.
- Connect a Multimeter in series with the terminal post. Refer to Troubleshooting Table 2-2 Trouble No. 4 Step 1.
- Loosen the locknut on the shaft of the bias potentiometer and turn the shaft with a screwdriver until a reading of 8.75 mA is obtained for 20 mA operation or a reading of 12.25 mA is obtained for 60-mA operation.
- Tighten the locknut and recheck the adjustment.
- Turn off power switch.
- Disconnect the multimeter and reconnect the strap between the BIAS TEST MA terminals.
- Readjust the range. Refer to TM 11-5815-238-10.

## Section VII. PREPARATION FOR STORAGE AND SHIPMENT

### 2-25. SECURITY PROCEDURES

Refer to security procedures listed in the Standard Operating Procedures for the operating organization.

### 2-26. DISASSEMBLY OF EQUIPMENT

#### a. Teletypewriter Set.

- Disconnect signal lines and power cords.
- Remove chad bin.
- Remove legs from table.
- Remove roll of paper tape from tape reel.

#### b. Teletypewriter Reperforator-Transmitter.

- Disconnect signal lines and power cords.
- Remove chad bin and its mounting equipment, tape guide, tape storage bin assembly and its mounting equipment.
- Remove mounting equipment attaching reperforator-transmitter to table and remove reperforator-transmitter.

### 2-27. TYPES OF STORAGE

- Short term (administrative) = 1 to 45 days. All equipment in administrative storage must be able to be made ready within 24 hours for use on a mission. Before placing any item in administrative storage, perform the next scheduled PMCS and correct or repair any deficiencies you find. The administrative storage site should provide required protection from extreme weather conditions and allow you to reach the equipment for visual inspections or exercises when applicable.
- Intermediate = 46 to 180 days.
- Long term or flyable = no time limit.

**APPENDIX A**  
**REFERENCES**

**A-1. INTRODUCTION**

Following is a list of all forms, technical bulletins and technical manuals referenced in this manual.

**A-2. FORMS**

Equipment Inspection and Maintenance Worksheet ..... DA Form 2404

Quality Deficiency Report ..... Form SF 368

Recommended Changes to Equipment Technical Manuals ..... DA Form 2028-2

Recommended Changes to Publications and Blank Forms ..... DA Form 2028

**A-3. TECHNICAL BULLETINS**

Field Instructions for Painting and Preserving Electronics Command  
Equipment Including Camouflage Pattern Painting of Electronic  
Equipment Shelter ..... TB 43-0118

**A-4. TECHNICAL MANUALS**

Operator's Manual: Teletypewriter Sets

AN/GGC-3, AN/GGC-3A, AN/GGC-53, AN/GGC-53A (NSN  
5815-01-017-0956) and Teletypewriter Reperforator-Transmitters TT-  
76/GGC, TT-76A/GGC, TT-76BIGGC, TT-76C/GGC, TT-6991GGC, TT-  
699A/GGC, TT-699B/GGC, (NSN 5815-01-017-9166) and TT-699C/GGC  
(NSN 5815-01-017-9166) ..... TM 11-5815-238-10

Organizational Maintenance Repair Parts and Special Tools List:  
Teletypewriter Sets AN/GGC-3, AN/GGC-3A, ANIGGC-53, ANIGGC-53A  
(NSN 5815-01,-017-0956) and Teletypewriter Reperforator-Transmitters  
TT-76/GGC, TT-76AIGGC, TT-76B/GGC, TT-76C/GGC, TT-6991GGC, TT-  
699A/GGC, TT-699B/GGC (NSN 5815-01-017-9166) and TT-699CIGGC  
(NSN 5815-01-017-9166) ..... TM 11-5815-238-20P

Operator's, Organizational, Direct Support Maintenance Manual:  
Multimeter AN/USM-451 (NSN 6625-01-060-6804) ..... TM 11-6625-2953-14

Procedures for Destruction of Electronic Materiel to Prevent Enemy Use  
(Electronics Command) ..... TM 750-244-2

The Army Maintenance Management System (TAM MS) ..... TM 38-750

**A-5. MISCELLANEOUS PUBLICATIONS**

Consolidated Index of Army Publications and Blank Forms ..... DA Pam 310-1

Sets, Kits, and Outfits, Component List: Tool Equipment TE-50-B ..... SM 11-4-5180-S05

## APPENDIX B MAINTENANCE ALLOCATION

---

### Section I. INTRODUCTION

#### B-1. General

This appendix provides a summary of the maintenance operations for AN/GGC-3(\*) or AN/GGC-53(\*). It authorizes categories of maintenance for specific maintenance functions on repairable items and components and the tools and equipment required to perform each function. This appendix may be used as an aid in planning maintenance operations.

#### B-2. Maintenance Function

Maintenance functions will be limited to and defined as follows:

*a. Inspect.* To determine the serviceability of an item by comparing its physical, mechanical, and/or electrical characteristics with established standards through examination.

*b. Test.* To verify serviceability and to detect incipient failure by measuring the mechanical or electrical characteristics of an item and comparing those characteristics with prescribed standards.

*c. Service.* Operations required periodically to keep an item in proper operating condition, i.e., to clean (decontaminate), to preserve, to drain, to point, or to replenish fuel, lubricants, hydraulic fluids, or compressed air supplies.

*d. Adjust.* To maintain, within prescribed limits, by bringing into proper or exact position, or by setting the operating characteristics to the specified parameters.

*e. Align.* To adjust specified variable elements of an item to bring about optimum or desired performance.

*f. Calibrate.* To determine and cause corrections to be made or to be made or to be adjusted on instruments or test measuring and diagnostic equipments used in precision measurement. Consists of comparisons of two instruments, one of which is a certified standard of known accuracy, to detect and adjust any discrepancy in the accuracy of the instrument being compared.

*g. Install.* The act of emplacing, seating, or fixing into position an item, part, module (component or assembly) in a manner to allow the proper functioning of the equipment or system.

*h. Replace.* The act of substituting a serviceable like type part, subassembly, or module (component or assembly) for an unserviceable counterpart.

*i. Repair.* The application of maintenance service (inspect, test, service, adjust, align, calibrate, replace) or other maintenance actions (welding, grinding, riveting, straightening, facing, remachining, or resurfacing) to restore serviceability to an item by correcting specific damage, fault, malfunction, or failure in a part, subassembly, module (component or assembly), end item, or system.

*j. Overhaul.* That maintenance effort (service/action) necessary to restore an item to a completely serviceable/operational condition as prescribed by maintenance standards (i.e., DMWR) in appropriate technical publications. Overhaul is normally the highest degree of maintenance performed by the Army. Overhaul does not normally return an item to like new condition.

*k. Rebuild.* Consists of those services/actions necessary for the restoration of unserviceable equipment to a like new condition in accordance with original manufacturing standards. Rebuild is the highest degree of materiel maintenance applied to Army equipment. The rebuild operation includes the act of returning to zero those age measurements (hours, miles, etc.) considered in classifying Army equipment/components.

#### B-3. Column Entries

*a. Column 1, Group Number.* Column 1 lists group numbers, the purpose of which is to identify components, assemblies, subassemblies, and modules with the next higher assembly.

*b. Column 2, Component/Assembly.* Column 2 contains the noun names of components, assemblies, subassemblies, and modules for which maintenance is authorized.

c. *Column 3, Maintenance Functions.* Column 3 lists the functions to be performed on the item listed in column 2. When items are listed without maintenance functions, it is solely for purpose of having the group numbers in the MAC and RPSTL coincide.

d. *Column 4, Maintenance Category.* Column 4 specifies, by the listing of a "work time" figure in the appropriate subcolumn(s), the lowest level of maintenance authorized to perform the function listed in column 3. This figure represents the active time required to perform that maintenance function at the indicated category of maintenance. If the number or complexity of the tasks within the listed maintenance function vary at different maintenance categories, appropriate "work time" figures will be shown for each category. The number of task-hours specified by the "work time" figure represents the average time required to restore an item (assembly, subassembly, component, module, end item or system) to a serviceable condition under typical field operating conditions. This time includes preparation time, troubleshooting time, and quality assurance/quality control time in addition to the time required to perform the specific tasks identified for the maintenance functions authorized in the maintenance allocation chart. Subcolumns of column 4 are as follows:

- C - Operator/Crew
- O - Organizational
- F - Direct Support
- H - General Support
- D - Depot

e. *Column 5, Tools and Equipment.* Column 5 specifies by code, those common tool sets (not individual tools) and special tools, test, and support equipment required to perform the designated function.

f. *Column 6, Remarks.* Column 6 contains an alphabetic code which leads to the remarks in section IV, Remarks, which is pertinent to the item opposite the particular code.

**B-4. Tool and Test Equipment Requirements (Sect. III)**

a. *Tool or Test Equipment Reference Code.* The numbers in this column coincide with the numbers used in the tools and equipment column of the MAC. The numbers indicate the applicable tool or test equipment for the maintenance functions.

b. *Maintenance Category.* The codes in this column indicate the maintenance category allocated the tool or test equipment.

c. *Nomenclature.* This column lists the noun name and nomenclature of the tools and test equipment required to perform the maintenance functions.

d. *National/NA TO Stock Number.* This column lists the National/NATO stock number of the specific tool or test equipment.

e. *Tool Number.* This column lists the manufacturer's part number of the tool followed by the Federal Supply Code for manufacturers (5-digit) in parentheses.

**B-5. Remarks (Sect. IV)**

a. *Reference Code.* This code refers to the appropriate item in section II, column 6.

b. *Remarks.* This column provides the required explanatory information necessary to clarify items appearing in section II.

**Section II. MAINTENANCE ALLOCATION CHART  
TELETYPEWRITER SETS AN/GGC-3, AN/GGC-3A, AN/GGC-53, AND AN/GGC-53A**

(1) Group Number	(2) Component/ Assembly	(3) Maintenance Function	(4) Maintenance Category					(5) Tools and Equipment	(6) Remarks
			C	O	F	H	D		
00	Teletypewriter Sets AN/GGC-3, AN/GGC-3A, AN/GGC-53 & AN/GGC-53A	INSPECT	0.1						F A B C E G
		SERVICE	0.3						
		SERVICE		0.5				1	
		SERVICE			1.5			1.2	
		ADJUST	0.2						
		TEST	0.5						
01	Teletypewriters TT-76(*)/GGC and TT-699(*)/GGC	TEST			3.0			3,4,5,6,7	F A B C E G
		OVERHAUL					15.0	1-7	
		INSPECT	0.1						
		SERVICE	0.3						
		SERVICE		0.5				1	
		SERVICE			1.5			1,2	
0101	Motor, Universal	ADJUST	0.2						1,2 1.2,3 1-4,6
		TEST	0.5						
		TEST			3.0			3,4,5,6,7	
		REPAIR			4.0			1,2	
		OVERHAUL					15.0	1-7	
		OVERHAUL							
0102	Terminal Box Assembly	REPLACE			1.0			1,2	D
		REPAIR				3.0		1.2,3	
		OVERHAUL					6.0	1-4,6	
0102	Terminal Box Assembly	TEST			0.5			3,6	D
		REPAIR			1.0			7 1,2	

**Section II. MAINTENANCE ALLOCATION CHART - Continued**  
**TELETYPEWRITER SETS ANIGGC-3, ANIGGC-3A, ANIGGC-53, ANIGGC-53A**

(1) Group Number	(2) Component/ Assembly	(3) Maintenance Function	(4) Maintenance Category					(5) Tools and Equipment	(6) Remarks
			C	O	F	H	D		
010201	Circuit Card Assembly, Transmitter	REPLACE REPAIR			0.5		1.8	1,2 1-3,6,7	D
010202	Circuit Card Assembly, Receiver	REPLACE REPAIR			0.5		1.8	1,2 1-3,6,7	D
010203	Circuit Card Assembly, Selector Magnet Driver	REPLACE REPAIR			0.5		1.8	1,2 1-3,6,7	D
010204	Circuit Card Assembly, Terminal Box	REPLACE REPAIR			0.5		1.8	1,2 1-3,6,7	D
02	Table RN-52/GGC, FN-108/GGC	REPAIR				3.0		1,2	
03	Case CY-1110/GGC	REPAIR				5.0		1,2	



**TOOLS AND TEST EQUIPMENT REQUIREMENTS  
TELETYPEWRITER SETS AN/GGC-3, AN/GGC-3A, AN/GGC-53, AN/GGC-53A**

Tool or Test Equipment Ref Code	Maintenance Category	Nomenclature	National/NATO Stock Number	Tool Number
1	O,F,H,D	Tool Kit, Teletypewriter Equipment TF-50B	5180-00-356-4602	
2	F,H,D	Tool Equipment TE-111	5180-00-408-1877	
3	O,F,H,D	Multimeter AN/USM-451	6625-01-060-6804	
4	F,H,D	Teletypewriter Test Set AN/GGM-1	6625-00-897-5505	
5	F,H,D	Test Set TS-2/TG	6625-00-243-5173	
6	F,H,D	Test Set, Telegraph ANIGGM-15(V)	6625-00-442-6131	
7	F,H,D	Voltmeter ME-30/U	6625-00-643-1670	

Reference Code	Remarks
A	Replaces fuses, lamps, lens indicators
B	Performs interior service including lubrication
C	Adjusts Rangefinder and Motor speed
D	Low-leveled equipment (AN/GGC-53(*) only)
E	Operational test.
F	Replenishes paper tape, replaces inking ribbon, empties chad bin.
G	Performs resistance, voltage and current measurements to determine condition of circuits. Tests system line up, conducts distortion test.

## APPENDIX C

EXPENDABLE SUPPLIES AND MATERIALS LIST

---

## Section I. INTRODUCTION

**C-1. Scope**

This appendix lists expendable supplies and materials you will need to operate and maintain the AN/GGC-3(\*) or AN/GGC-53(\*). These items are authorized to you by CTA 50-970, Expendable Items (Except Medical, Class V, Repair Parts, and Heraldic Items).

**C-2. Explanation of Columns**

*a. Column 1 - Item Number.* This number is assigned to the entry in the listing and is referenced in the narrative instructions to identify the material (e.g., "Use cleaning compound, item 5, App. D").

*b. Column 2 - Level.* This column identifies the lowest level of maintenance that requires the listed item.

C	-	Operator/Crew
O	-	Organizational Maintenance
F	-	Direct Support Maintenance
H	-	General Support Maintenance

*c. Column 3 - National Stock Number.* This is the National stock number assigned to the item; use it to request or requisition the item.

*d. Column 4 - Description.* Indicates the Federal item name and, if required, a description to identify the item. The last line for each item indicates the part number followed by the Federal Supply Code for Manufacturer (FSCM) in parentheses, if applicable.

*e. Column 5 - Unit of Measure (U/M).* Indicates the measure used in performing the actual maintenance function. This measure is expressed by a two-character alphabetical abbreviation (e.g., ea, in, pr). If the unit of measure differs from the unit of issue, requisition the lowest unit of issue that will satisfy your requirements.

APPENDIX C

Section II. EXPENDABLE SUPPLIES AND MATERIALS LIST

(1) Item Number	(2) Level	(3) National Stock Number	(4) Description	(5) U/M
1	C	7510-00-082-2648	Ribbon, Printing Teletypewriter DD-R-311D	EA
2	C	7350-00-634-6237	Tape, Teletypewriter UU-T-120	EA
3	C	6180-00-105-3084	Trichlorotrifluoroethane (80244)	QT
4	O	9150-00-223-4129	Lubricating oil	OZ
5	F		Cleaning solvent (SD)	OZ

## GLOSSARY

**ALTERNATING CURRENT (AC).** Electrical current that is continually changing in magnitude and periodically reverting in polarity.

**DIRECT CURRENT (DC).** Electric current (waves) that flows in only one direction and remains essentially constant in magnitude.

**AMPERE.** Basic unit of electrical current flow.

**MILLIAMPERE (MA).** A measure for a small amount of electrical current.

**MICROAMPERE (UA).** One-millionth of an ampere.

**BIAS.** To influence or dispose in one direction.

**BIAS METER.** Measures the amount of marking or spacing bias teletype signals.

**CURRENT.** Flow of electric charge or rate of such flow.

**FULL DUPLEX.** Process of transmitting and receiving information at the same time.

**HALF-DUPLEX.** Permits operation in either direction but not at same time.

**FUSE.** To open a circuit when excessive current exists in a circuit.

**RECEIVE.** To receive a signal or message.

**TRANSMIT.** To send a signal or message.

**TRANSMITTER-DISTRIBUTOR.** Translates code perforations in paper tape into electrical impulses and sends them to receiver units.

**VOLTAGE.** Electromotive force measured in volts.

### NOTE

For more terms, see TM 11-5815-238-10.

INDEX

	PAGE		PAGE
<b>A</b>			
Maintenance procedures	2-29		
Assembly	2-5	Major components, location	1-2
<b>C</b>			
Checking unpacked equipment	2-4	Neutral operation	2-9
Cleaning	2-30	Nomenclature cross-reference list	1-2
Components:			
Assembly	2-5		
List	1-2		
Connections:		One-way operation	2-12
Ground and power	2-6		
Cross-reference list, nomenclature	1-2		
<b>D</b>			
Data and description, equipment	1-2	Painting	2-30
Destruction of Army materiel	1-2	Polar operation	2-10
Differences between models	1-3	Preparation for storage and shipment	2-32
Duplex operation	2-11	Preventive maintenance checks and services (PMCS):	
		Table	2-17
		Tools required	2-15
		Principles of operation, technical	1-3
		Purpose of equipment	1-1
<b>E</b>			
Equipment:			
Data and description	1-2		
Disassembly	2-32		
<b>F</b>			
Forms, records, reports	1-2	Records, reports, forms	1-2
		Repair parts, special tools	2-1
		Reports, forms, records	1-2
<b>H</b>			
Half duplex and send only	2-12	Scope	1-1
Half duplex operation	2-12	Send only and local preparation of tape	2-12
		Signal circuit-connections:	
		for TT-76(*)/GGC	2-10
		for TT-699(*)/GGC	2-15
<b>I</b>			
Inspection	2-18		
Installation	2-5		
<b>L</b>			
List, components	1-2	Technical principles of operation	1-3
Local test circuit	2-19	Testing	2-30
Location, major components	1-2	Troubleshooting:	
Lubrication	2-30	Table	2-20
		Types of storage	2-32
<b>M</b>			
<b>N</b>			
<b>O</b>			
<b>P</b>			
<b>R</b>			
<b>S</b>			
<b>T</b>			
<b>U</b>			
		Unpacking	2-1

By Order of the Secretary of the Army:

Official:

JOHN A. WICKHAM JR.  
*General, United States Army*  
*Chief of Staff*

ROBERT M. JOYCE  
*Major General, United States Army*  
*The Adjutant General*

DISTRIBUTION:

To be distributed in accordance with DA Form 12-51A, Organizational Maintenance requirements for AN/GGC-3.

U. S. GOVERNMENT PRINTING OFFICE : 1992 O - 311-831 (44716)

RECOMMENDED CHANGES TO EQUIPMENT TECHNICAL PUBLICATIONS

 <div style="border: 1px solid black; border-radius: 15px; padding: 5px; display: inline-block; margin-left: 20px;"> <p style="margin: 0;"><i>THEN...JOT DOWN THE DOPE ABOUT IT ON THIS FORM. CAREFULLY TEAR IT OUT, FOLD IT AND DROP IT IN THE MAIL.</i></p> </div>		SOMETHING WRONG WITH PUBLICATION	
		FROM: (PRINT YOUR UNIT'S COMPLETE ADDRESS)	
		DATE SENT	
PUBLICATION NUMBER		PUBLICATION DATE	PUBLICATION TITLE
IN THIS SPACE, TELL WHAT IS WRONG AND WHAT SHOULD BE DONE ABOUT IT.			
BE EXACT PIN-POINT WHERE IT IS			
PAGE NO.	PARA-GRAPH	FIGURE NO.	TABLE NO.
PRINTED NAME, GRADE OR TITLE AND TELEPHONE NUMBER		SIGN HERE	



## The Metric System and Equivalents

### Linear Measure

1 centimeter = 10 millimeters = .39 inch  
 1 decimeter = 10 centimeters = 3.94 inches  
 1 meter = 10 decimeters = 39.37 inches  
 1 dekameter = 10 meters = 32.8 feet  
 1 hectometer = 10 dekameters = 328.08 feet  
 1 kilometer = 10 hectometers = 3,280.8 feet

### Weights

1 centigram = 10 milligrams = .15 grain  
 1 decigram = 10 centigrams = 1.54 grains  
 1 gram = 10 decigrams = .035 ounce  
 1 decagram = 10 grams = .35 ounce  
 1 hectogram = 10 decagrams = 3.52 ounces  
 1 kilogram = 10 hectograms = 2.2 pounds  
 1 quintal = 100 kilograms = 220.46 pounds  
 1 metric ton = 10 quintals = 1.1 short tons

### Liquid Measure

1 centiliter = 10 milliliters = .34 fl. ounce  
 1 deciliter = 10 centiliters = 3.38 fl. ounces  
 1 liter = 10 deciliters = 33.81 fl. ounces  
 1 dekaliter = 10 liters = 2.64 gallons  
 1 hectoliter = 10 dekaliters = 26.42 gallons  
 1 kiloliter = 10 hectoliters = 264.18 gallons

### Square Measure

1 sq. centimeter = 100 sq. millimeters = .155 sq. inch  
 1 sq. decimeter = 100 sq. centimeters = 15.5 sq. inches  
 1 sq. meter (centare) = 100 sq. decimeters = 10.76 sq. feet  
 1 sq. dekameter (are) = 100 sq. meters = 1,076.4 sq. feet  
 1 sq. hectometer (hectare) = 100 sq. dekameters = 2.47 acres  
 1 sq. kilometer = 100 sq. hectometers = .386 sq. mile

### Cubic Measure

1 cu. centimeter = 1000 cu. millimeters = .06 cu. inch  
 1 cu. decimeter = 1000 cu. centimeters = 61.02 cu. inches  
 1 cu. meter = 1000 cu. decimeters = 35.31 cu. feet

## Approximate Conversion Factors

To change	To	Multiply by	To change	To	Multiply by
inches	centimeters	2.540	ounce-inches	Newton-meters	.007062
feet	meters	.305	centimeters	inches	.394
yards	meters	.914	meters	feet	3.280
miles	kilometers	1.609	meters	yards	1.094
square inches	square centimeters	6.451	kilometers	miles	.621
square feet	square meters	.093	square centimeters	square inches	.155
square yards	square meters	.836	square meters	square feet	10.764
square miles	square kilometers	2.590	square meters	square yards	1.196
acres	square hectometers	.405	square kilometers	square miles	.386
cubic feet	cubic meters	.028	square hectometers	acres	2.471
cubic yards	cubic meters	.765	cubic meters	cubic feet	35.315
fluid ounces	milliliters	29.573	cubic meters	cubic yards	1.308
pints	liters	.473	milliliters	fluid ounces	.034
quarts	liters	.946	liters	pints	2.113
gallons	liters	3.785	liters	quarts	1.057
ounces	grams	28.349	liters	gallons	.264
pounds	kilograms	.454	grams	ounces	.035
short tons	metric tons	.907	kilograms	pounds	2.205
pound-feet	Newton-meters	1.356	metric tons	short tons	1.102
pound-inches	Newton-meters	.11296			

## Temperature (Exact)

°F	Fahrenheit temperature	5/9 (after subtracting 32)	Celsius temperature	°C
----	------------------------	----------------------------	---------------------	----

**PIN: 054121-000**